

BIG PINE ACADEMY ADA ACCESS COMPLIANCE

RENOVATION 30220 OVERSEAS HIGHWAY BIG PINE KEY, FLORIDA

WILLIAM P. HORN
ARCHITECT, P.A.

915 EATON ST.
KEY WEST,
FLORIDA
33040

TEL (305) 296-8302
FAX (305) 296-1033

LICENSE NO.
AA 0003040

BIG PINE ACADEMY
ADA ACCESS
COMPLIANCE
RENOVATION
30220 OVERSEAS HWY.
BIG PINE KEY, FLORIDA



SITE DATA	
LAND USE :	SC (SUBURBAN COMMERCIAL)
FLOOD ZONE:	A E +8.0' NGVD
SITE AREA:	4 ACRES (174240 SF)
SETBACKS	
FRONT YARD SETBACK	=25'
SIDE YARD SETBACKS	=10'/15'
REAR YARD	=10'
ALL SETBACKS REMAIN UNCHANGED	
HEIGHT ALLOWED	= 35'-0" MAX
ADDITIONAL IMPERVIOUS AREA	= 752 SQFT
PROVIDING	63 CUBIC FEET OF SWALE VOLUME FOR NEW IMPERVIOUS ONLY

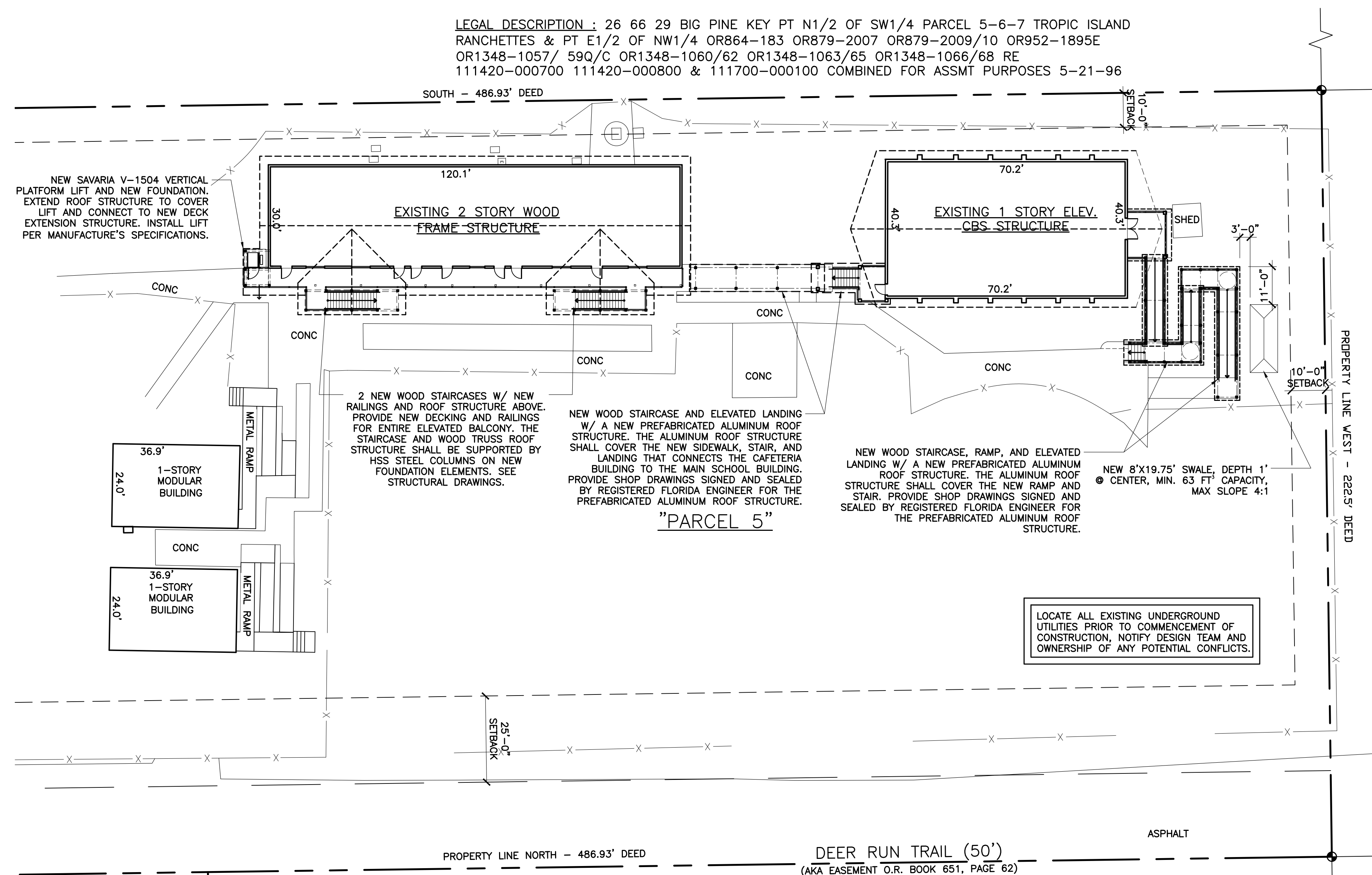

KEY PERSONNEL	
ARCHITECT:	STRUCTURAL ENGINEERING:
WILLIAM P. HORN ARCHITECT, P.A.	PENNONI
WILLIAM P. HORN, RA, LEED AP	VINCE BARNS, P.E.
915 EATON ST. KEY WEST, FL 33040 TEL. (305) 296-8302	5755 RIO VISTA DRIVE CLEARWATER, FL 33760 TEL. (727) 325-1251
MEP ENGINEERING:	SURVEYOR:
INNOVATIVE ENGINEERING GROUP INC.	FLORIDA KEYS LAND SURVEYING
SUDHIR GUPTA, PE, LEED AP	ERIC ISAACS, PROFESSIONAL SURVEYOR & MAPPER
2500 NW 79TH AVE., SUITE 240 DORAL, FL 33122 TEL. (305) 468-1783	19960 OVERSEAS HIGHWAY SUGARLOAF KEY, FL 33042 TEL. (305) 394-3690
OWNER:	
MONROE COUNTY SCHOOL DISTRICT	
DOUGLAS PRYOR FACILITIES PLANNER	
1310 UNITED STREET KEY WEST, FLORIDA 33040 TEL. (305) 293-1400 X53465	

LIST OF DRAWINGS	
A-1.0	SITE PLAN
AD-1.0	DEMOLITION PLAN
AD-2.0	DEMOLITION PLAN
A-2.0	PROPOSED FLOOR PLAN MAIN BUILDING
A-2.1	ENLARGED PLANS MAIN BUILDING
A-2.2	MAIN BUILDING ROOF PLAN
A-3.0	PROPOSED CAFETERIA FLOOR PLAN
A-4.0	MAIN BUILDING SECTIONS
A-4.1	MAIN BUILDING SECTIONS
A-4.2	MAIN BUILDING SECTIONS
A-5.0	MAIN BUILDING ELEVATIONS
A-5.1	CAFETERIA ELEVATIONS
A-6.0	CANOPY DETAILS
A-7.0	SPECIFICATIONS
S-0.1	STRUCTURAL SPECIFICATIONS
S-0.2	STRUCTURAL SPECIFICATIONS AND WIND LOADS
S-1.0	PARTIAL STAIR FOUNDATION PLAN
S-1.1	PARTIAL RAMP FOUNDATION PLANS AND DETAILS
S-1.2	STAIR ROOF FRAMING PLAN, SECTIONS AND DETAILS
S-2.0	DETAILS
S-2.1	SECTION AND DETAILS
E-1.0	PROPOSED ELECTRICAL PLANS
E-2.0	PROPOSED BATTERY BACKUP MODE
E-3.0	ELECTRICAL NOTES

SCOPE OF WORK
WORK INCLUDES REMOVE EXISTING STAIR AND RAILINGS @ MAIN SCHOOL BUILDING, REMOVAL OF EXISTING RAMP AND STAIRS @ CAFETERIA BUILDING. CONTRACTOR IS TO INSTALL 2 NEW STAIRCASES ON MAIN BUILDING WITH NEW HANDRAILS ON STAIR AND ALONG UPPER LEVEL. BASE BID FOR STAIRS IS TO BE WOOD CONSTRUCTION WITH A PREFABRICATED ALUMINUM STAIR ALTERNATIVE. THE STAIRS ARE TO BE COVERED WITH A ROOF STRUCTURE THAT TIES BACK INTO THE EXISTING ROOF. A NEW ELEVATOR LIFT IS TO BE INSTALLED ON THE SOUTH SIDE OF THE STRUCTURE WITH A NEW SLAB TO SUPPORT ELEVATOR PER ENGINEERED SPECIFICATIONS. RELOCATION OF WATER FOUNTAINS MAY BE NECESSARY.
THE CAFETERIA BUILDING SCOPE OF WORK WILL INCLUDE A NEW STAIRCASE TO THE SOUTH SIDE OF THE STRUCTURE AND A NEW STAIR WITH A RAMP ON THE NORTH SIDE OF THE STRUCTURE. BASE BID FOR THE STAIRS AND RAMP SHALL BE WOOD CONSTRUCTION, PROVIDE PREFABRICATED ALUMINUM RAMP AND STAIR ALTERNATIVE. BOTH THE STAIR AND RAMP SHALL HAVE A PREFABRICATED ALUMINUM ROOF STRUCTURE PER PLAN.
ALL PREFABRICATED ALUMINUM STRUCTURES WILL REQUIRE SHOP DRAWINGS SIGNED AND SEALED BY A REGISTERED FLORIDA ENGINEER.
CONTRACTOR WILL BE RESPONSIBLE TO COORDINATE WITH THE SCHOOL AND FACILITY MANAGER THE CONSTRUCTION SCHEDULE AND ACCESS TIMES. REVIEW THE DRAWINGS AND SPECIFICATIONS FOR THE FULL SCOPE OF WORK.

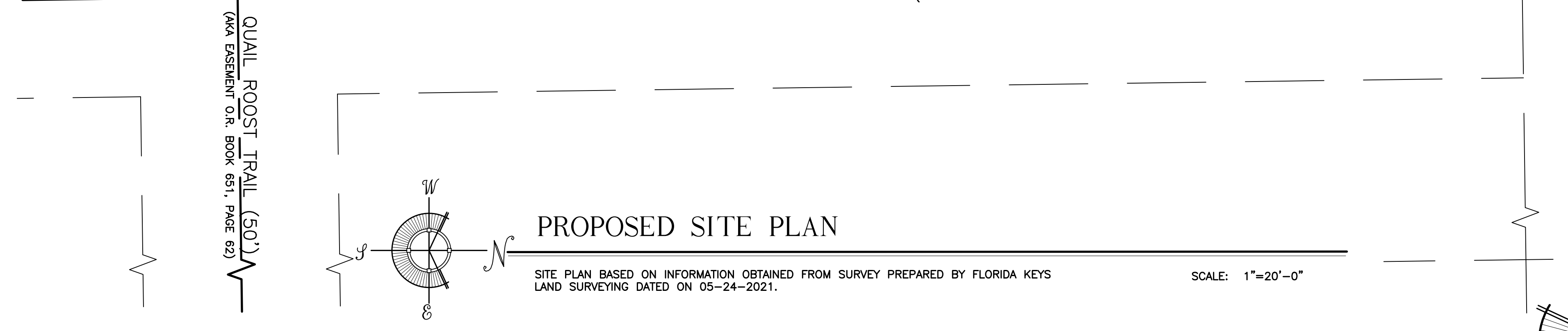

SEAL

DATE
01-28-2022 BID SET

REVISIONS

DRAWN BY
JFS

PROJECT NUMBER
2105

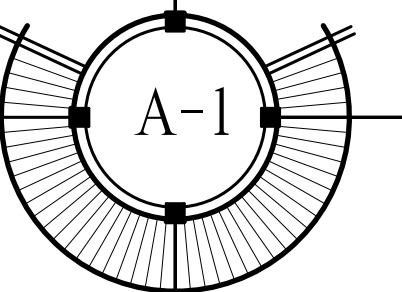

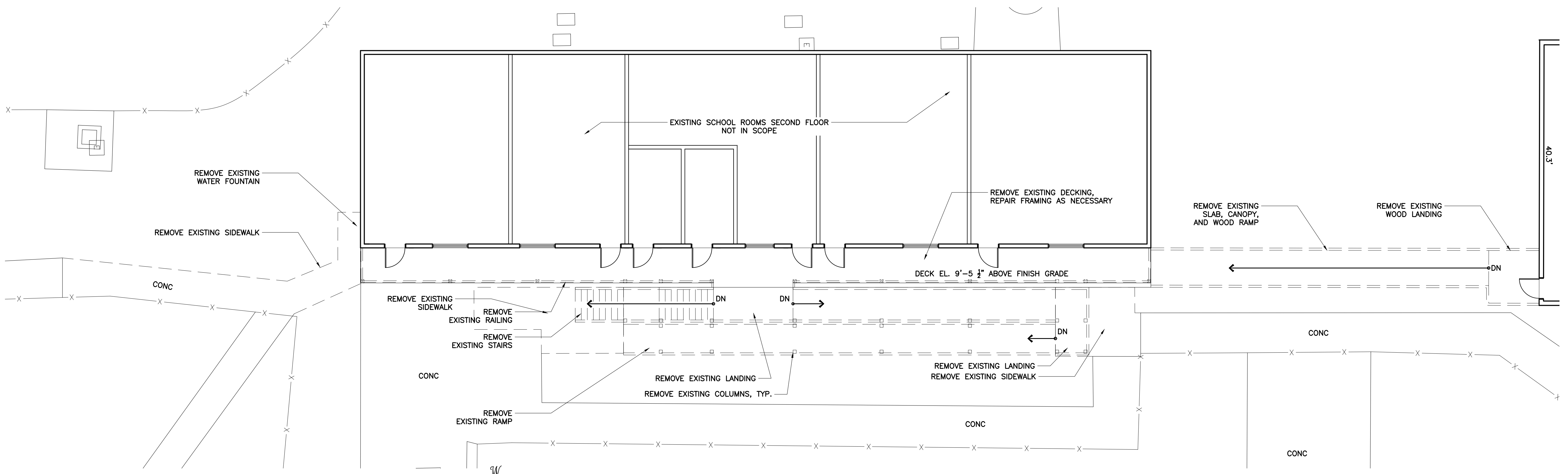

FIRST FLOOR DEMOLITION PLAN

SCALE: 1/8"=1'-0"

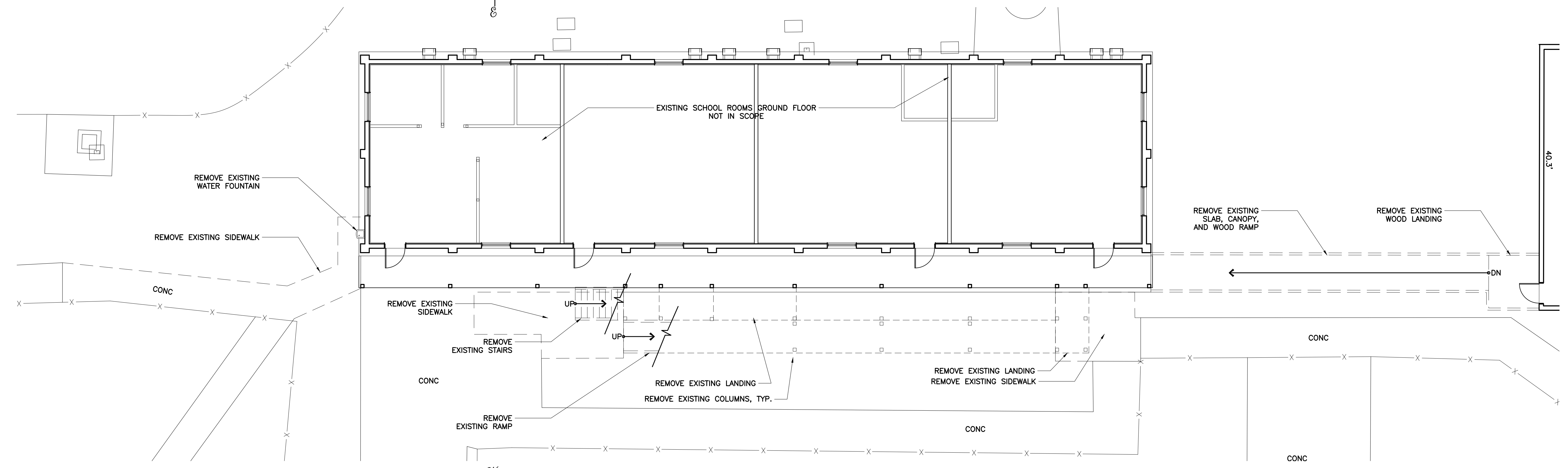

GROUND FLOOR DEMOLITION PLAN

SCALE: 1/8"=1'-0"

SEAL

DATE
01-28-2022 BID SET

REVISIONS

DRAWN BY
JFS

PROJECT
NUMBER
2105

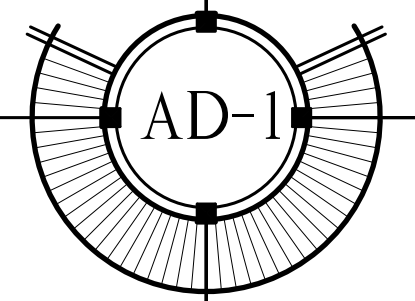

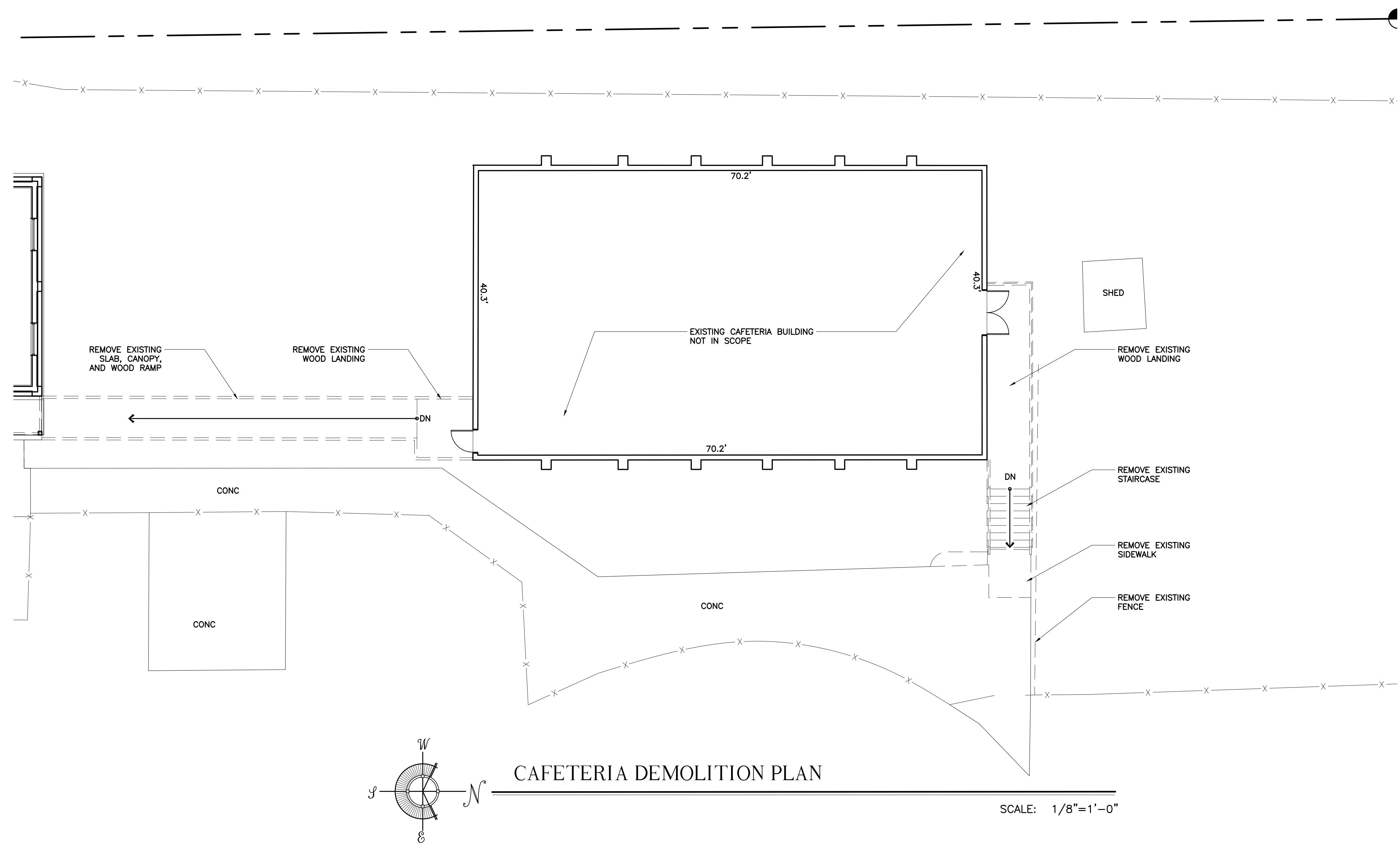

SEAL _____

DATE
01-28-2022 BID SET

REVISIONS _____

DRAWN BY
JFS

PROJECT
NUMBER
2105

BIG PINE ACADEMY ADA ACCESS COMPLIANCE RENOVATION
30220 OVERSEAS HIGHWAY
BIG PINE KEY, FLORIDA 33043

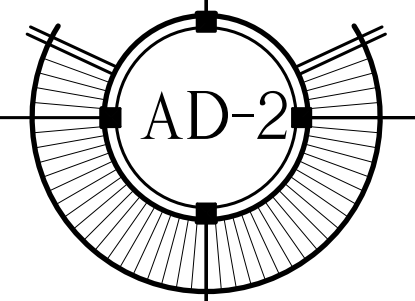

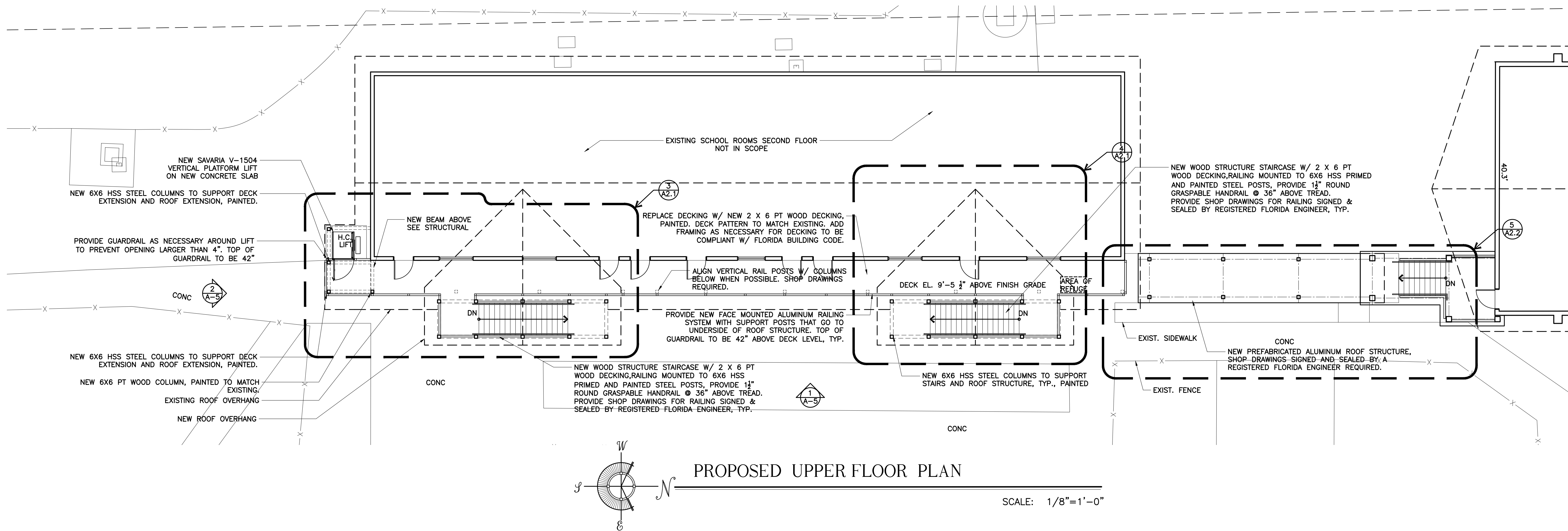
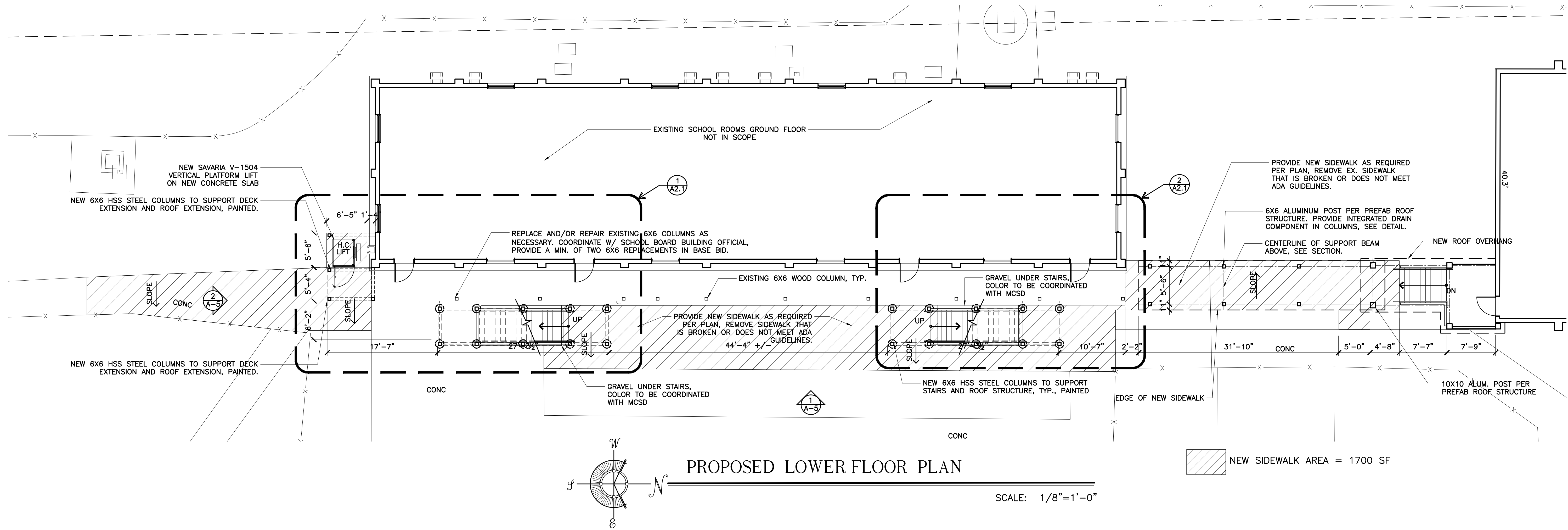

BIG PINE ACADEMY ADA ACCESS COMPLIANCE RENOVATION
30220 OVERSEAS HIGHWAY
BIG PINE KEY, FLORIDA 33043

SEAL

DATE
01-28-2022 BID SET

REVISIONS

DRAWN BY
JFS

PROJECT
NUMBER
2105

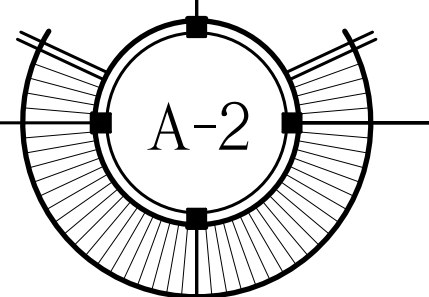

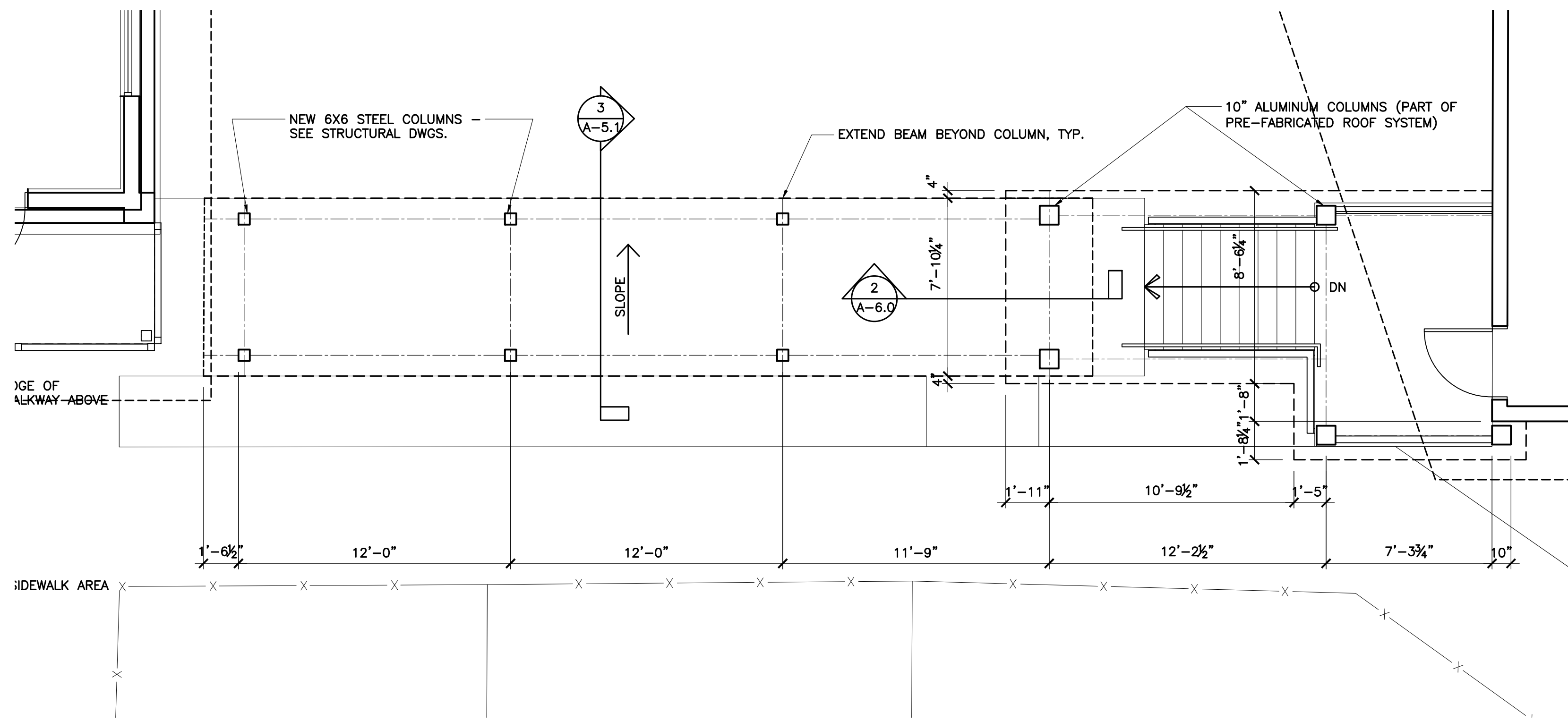

5
A-2.2
ENLARGED WALKWAY & ROOF STRUCTURE TO CAFETERIA
SCALE: 1/4"=1'-0"

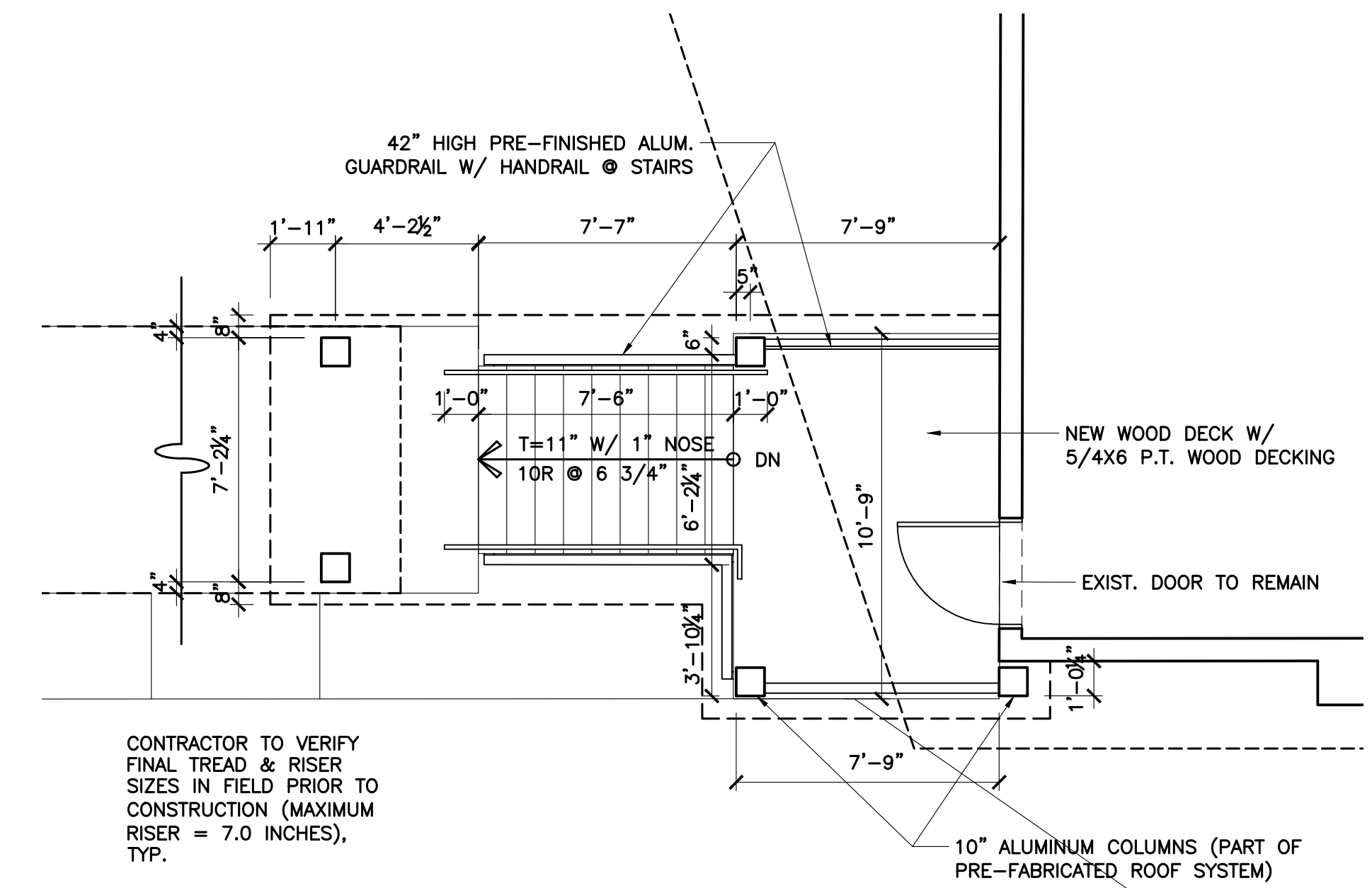

W
N
S
E
ENLARGED STAIRS TO CAFETERIA
SCALE: 1/2"=1'-0"

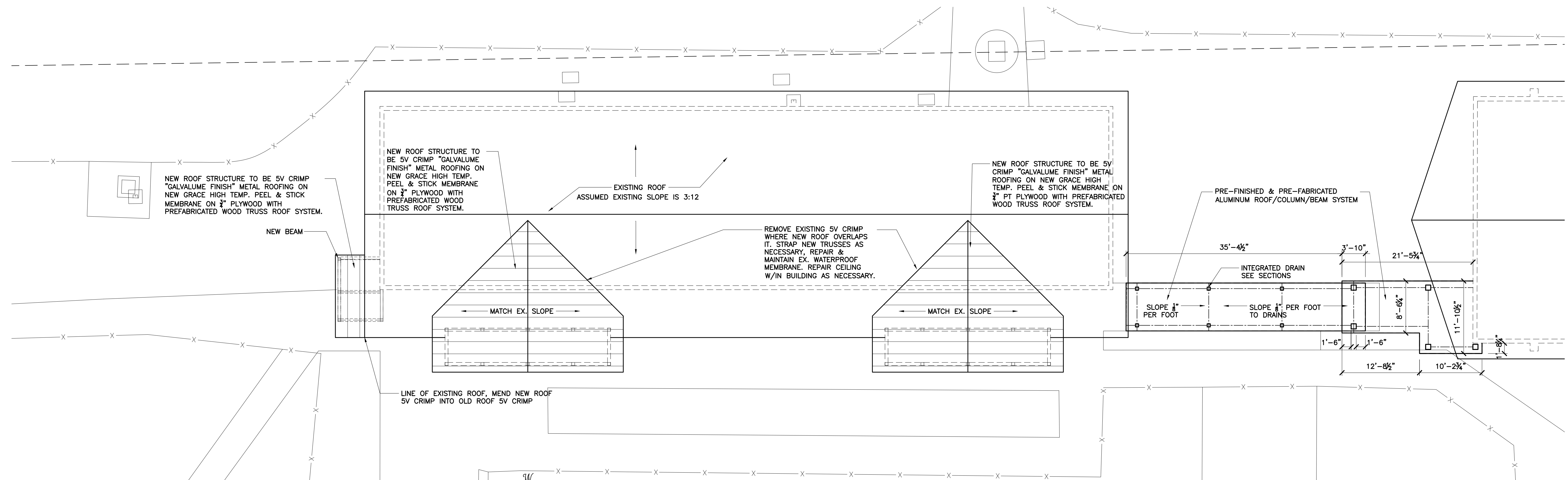

W
N
S
E
MAIN BUILDING ROOF PLAN
SCALE: 1/8"=1'-0"

SEAL

DATE
01-28-2022 BID SET

REVISIONS

DRAWN BY
JFS

PROJECT NUMBER
2105

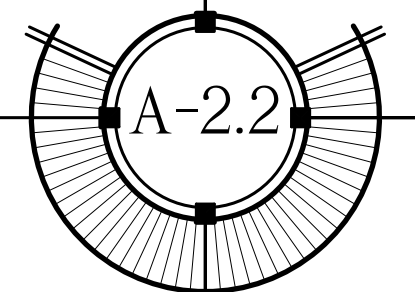

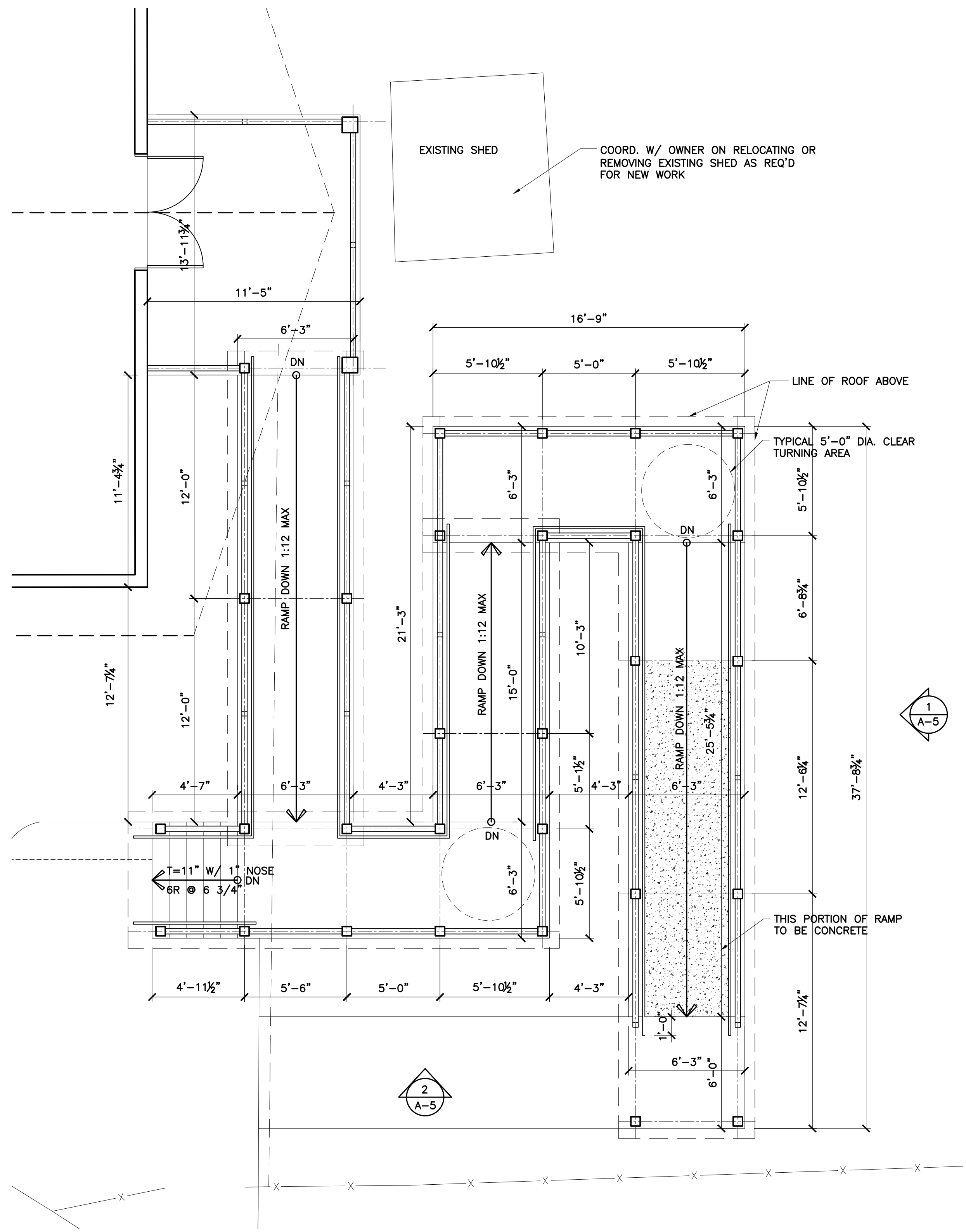

1
A-3 ENLARGED RAMP PLAN
SCALE: 1/4"=1'-0"

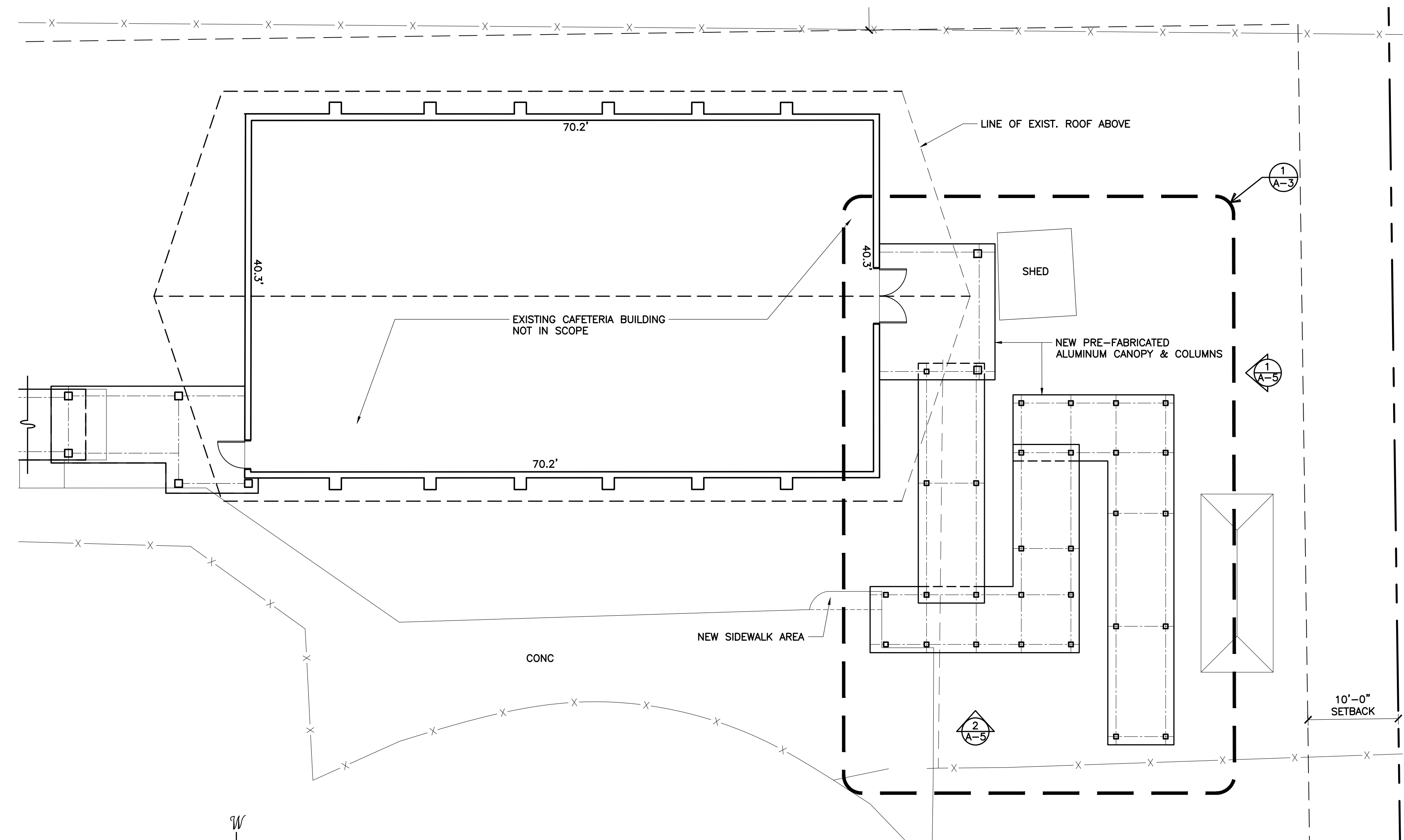

PROPOSED ROOF PLAN
SCALE: 1/8"=1'-0"

SEAL

DATE
01-28-2022 BID SET

REVISIONS

DRAWN BY
JFS

PROJECT
NUMBER
2105

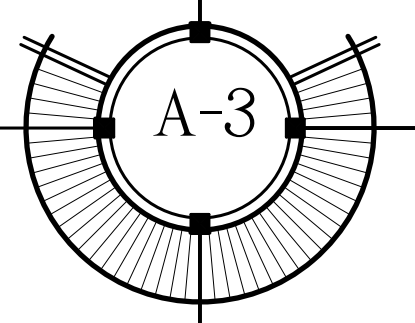

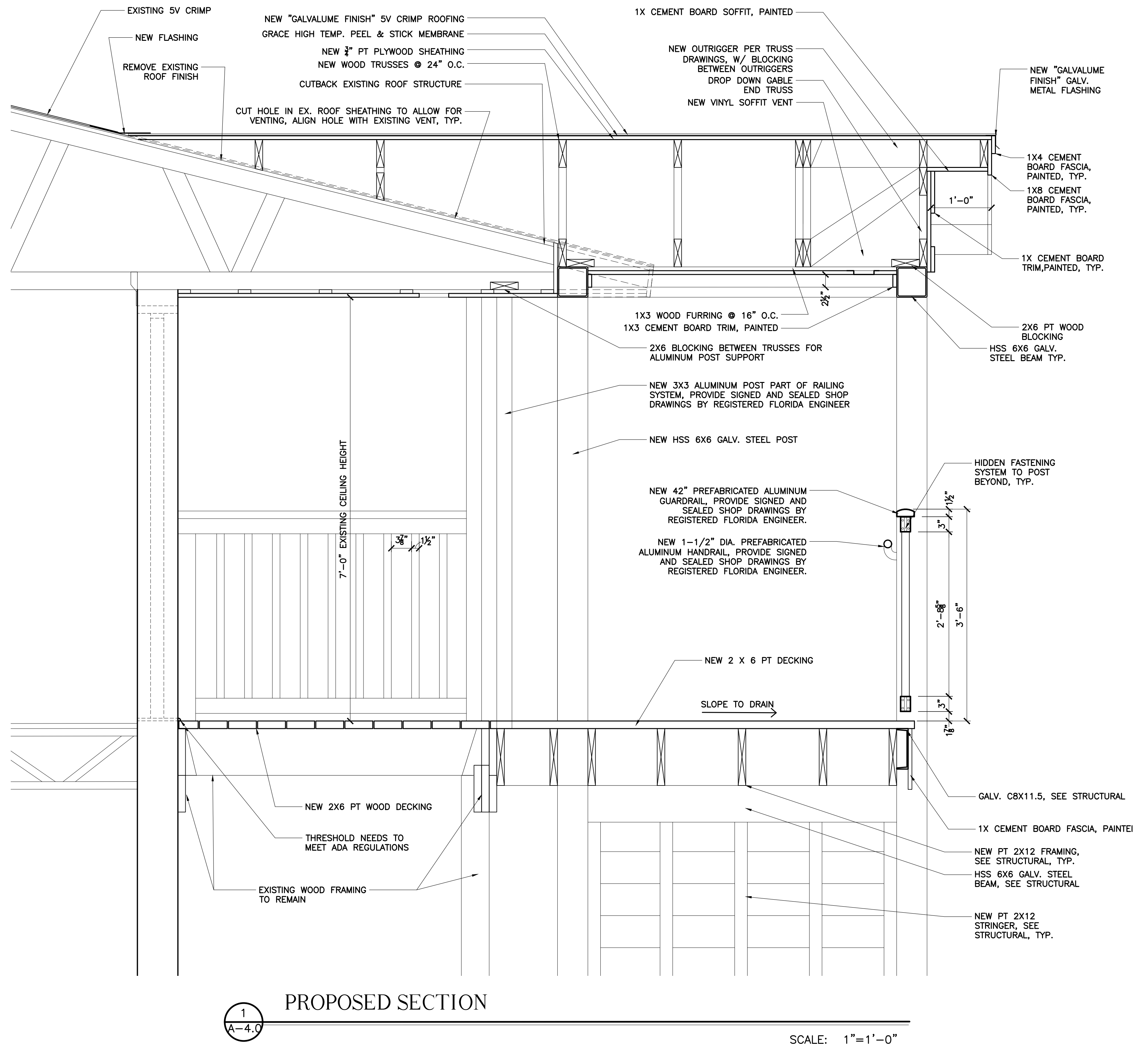
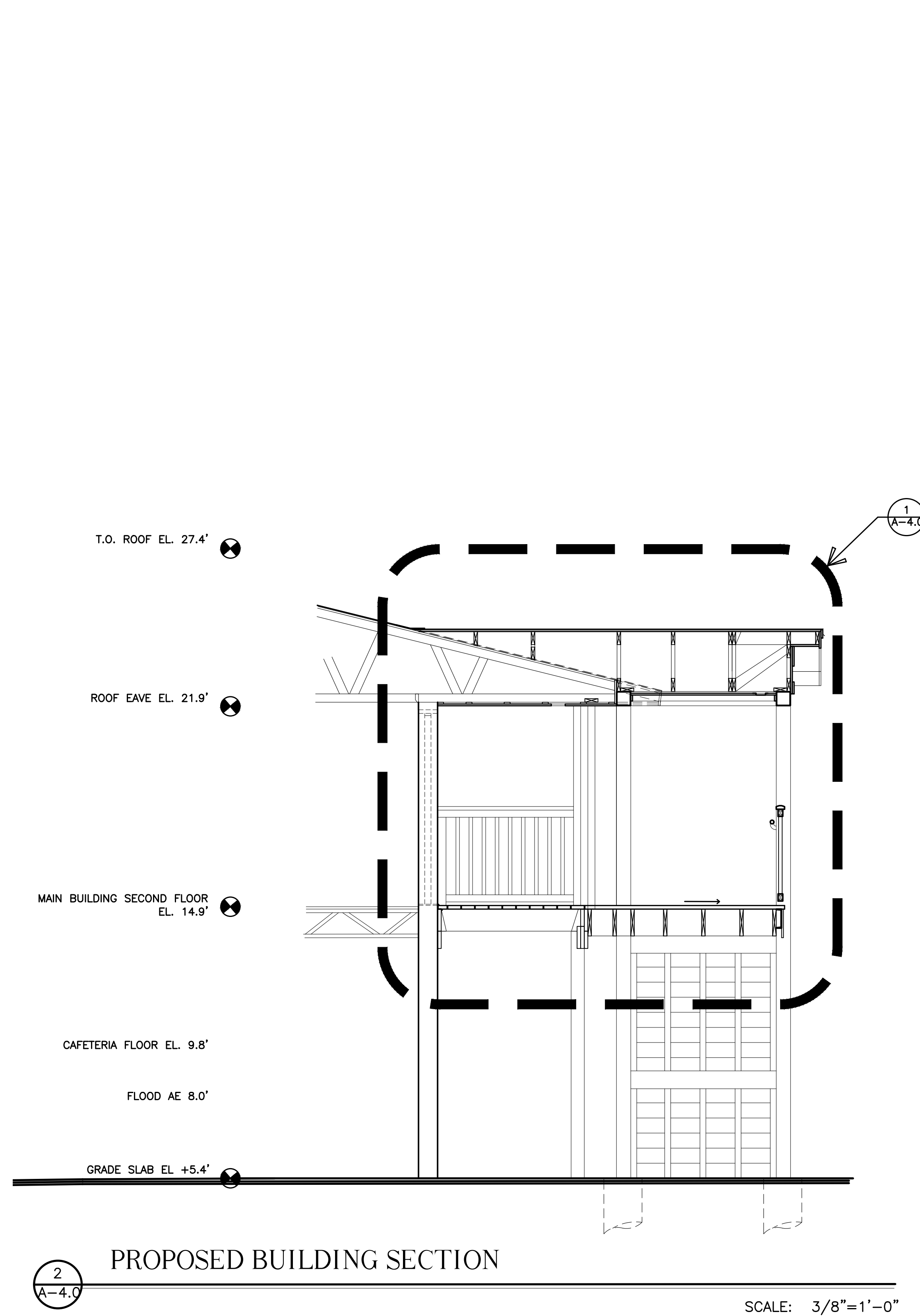

SEAL

DATE
01-28-2022 BID SET

REVISIONS

DRAWN BY
JFS

PROJECT NUMBER
2105

BIG PINE ACADEMY ADA ACCESS COMPLIANCE RENOVATION
30220 OVERSEAS HIGHWAY
BIG PINE KEY, FLORIDA 33043

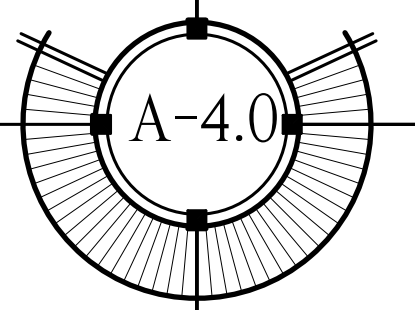

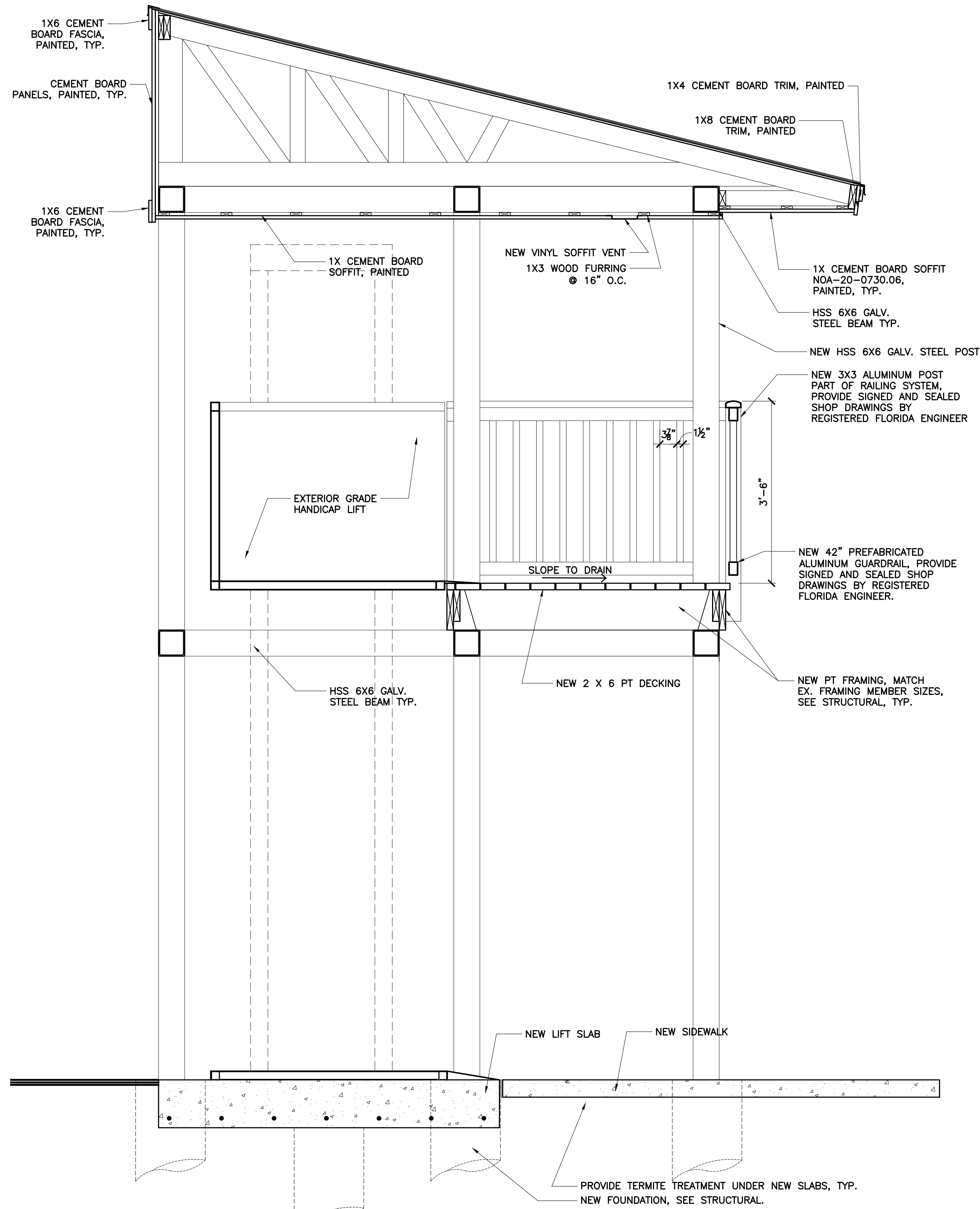

2
A-4.1
PROPOSED SECTION
SCALE: 3/4"=1'-0"

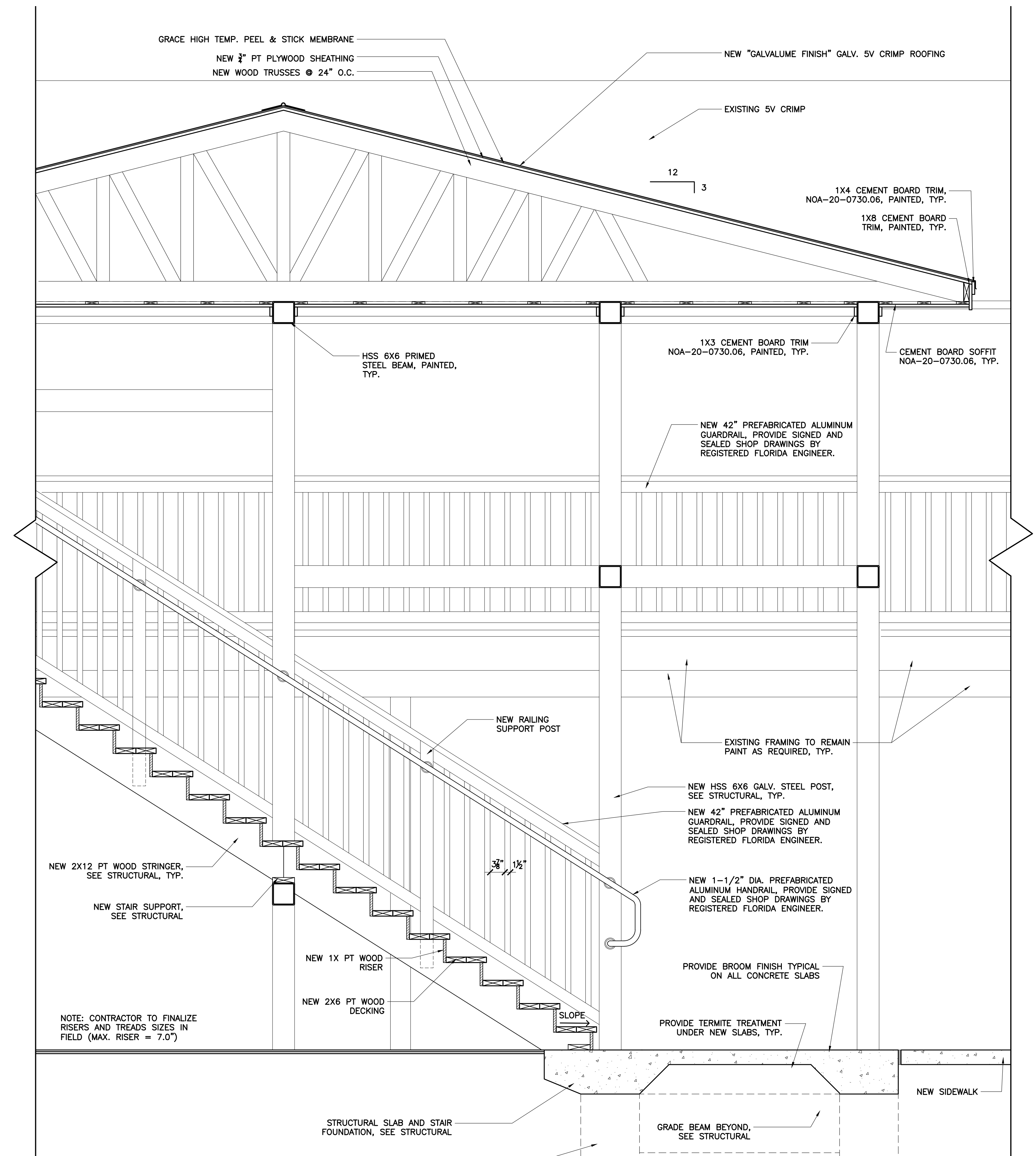

1
A-4.1
PROPOSED SECTION
SCALE: 3/4"=1'-0"

SEAL _____

DATE
01-28-2022 BID SET

REVISIONS _____

DRAWN BY
JFS

PROJECT NUMBER
2105

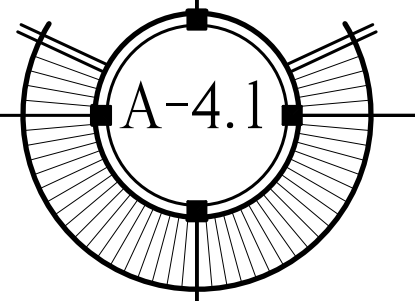

BIG PINE ACADEMY ADA ACCESS COMPLIANCE RENOVATION
30220 OVERSEAS HIGHWAY
BIG PINE KEY, FLORIDA 33043

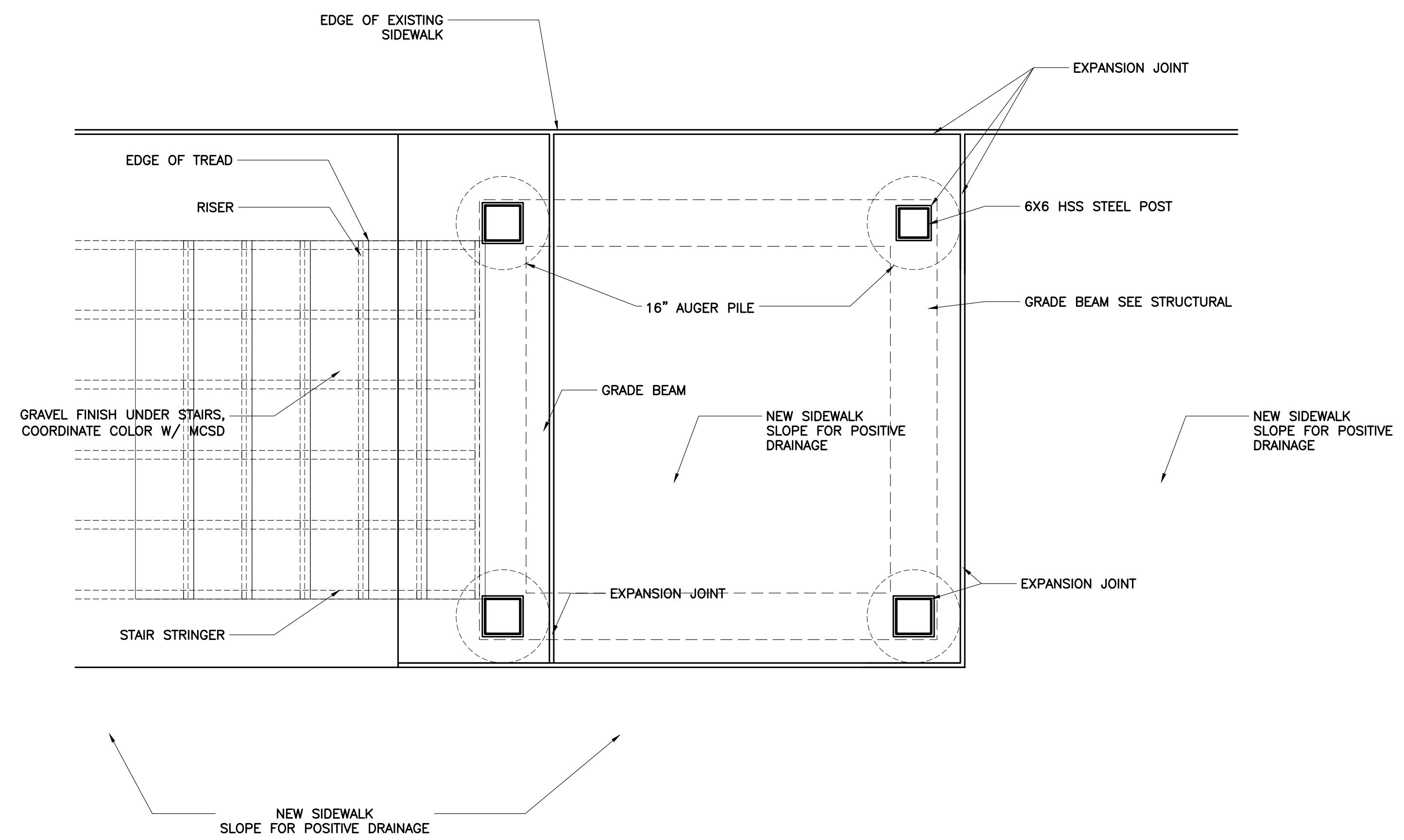
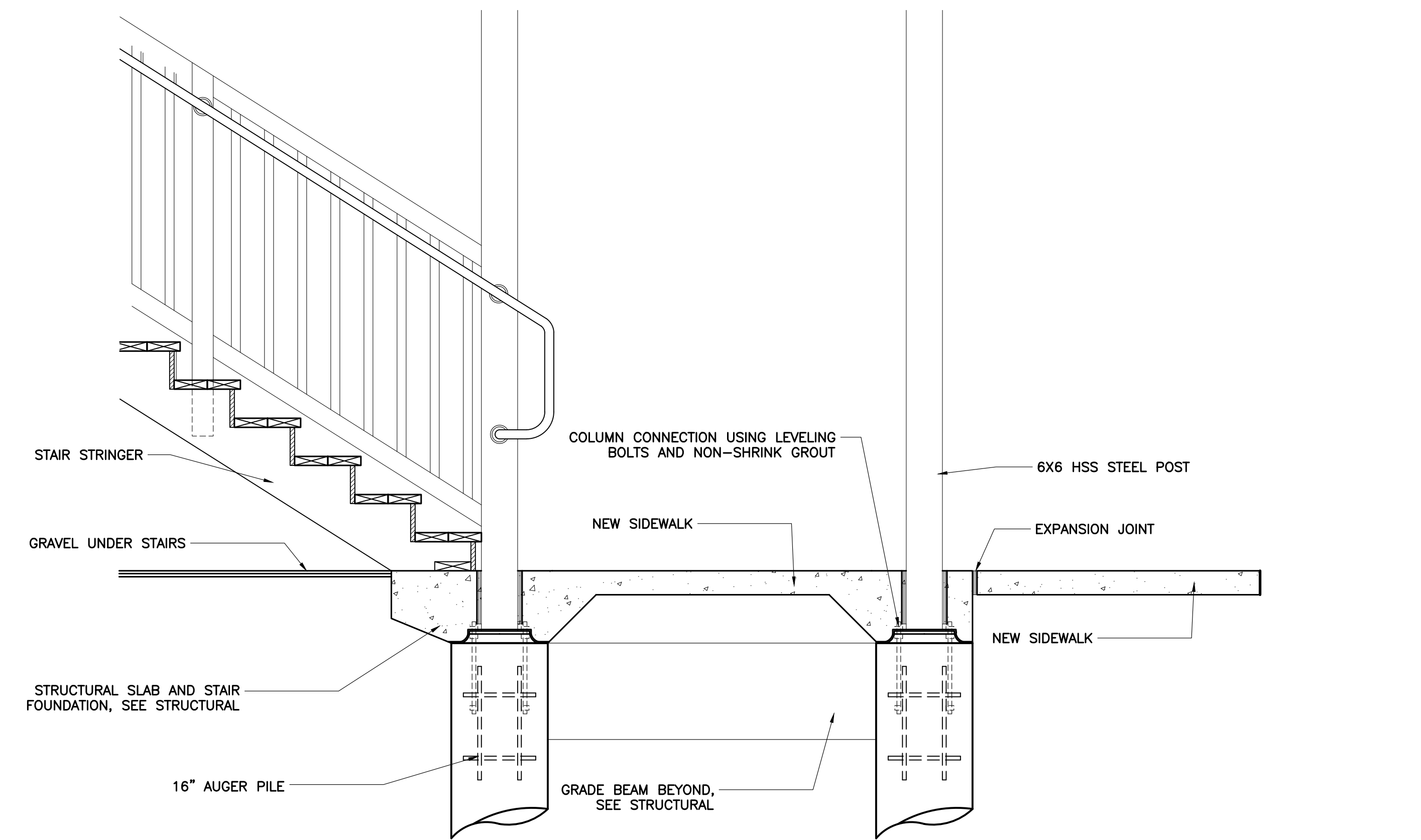

1
A-4.2

PROPOSED FOUNDATION @ BOTTOM OF STAIR

SCALE: 3/4" = 1'-0"

SEAL

DATE
01-28-2022 BID SET

REVISIONS

DRAWN BY
JFS

PROJECT
NUMBER
2105

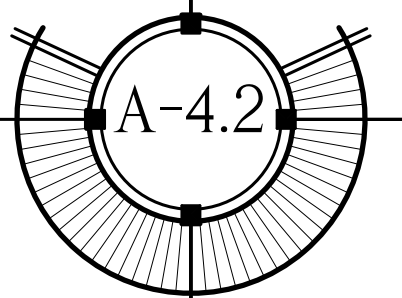

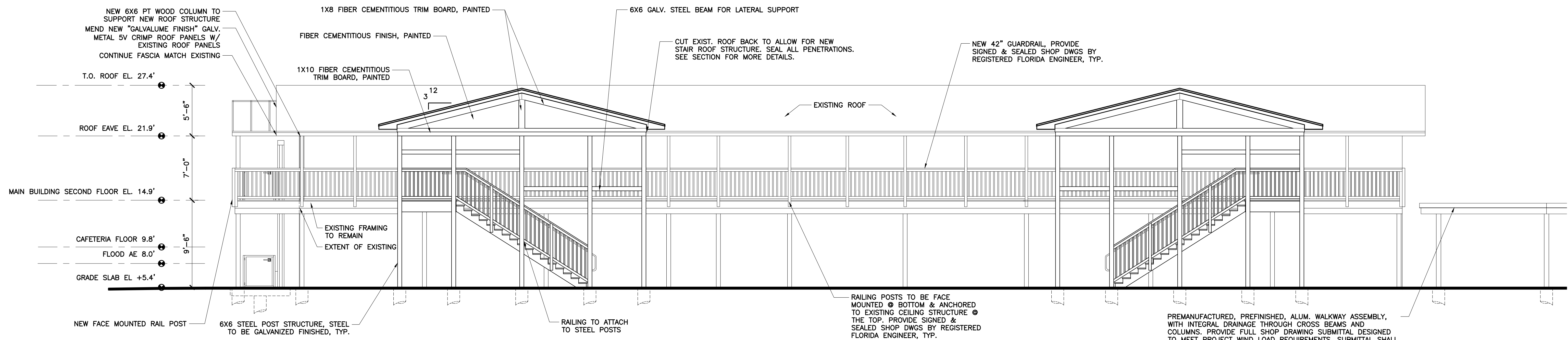

1
A-5

PROPOSED FRONT ELEVATION

SCALE: 3/16"=1'-0"

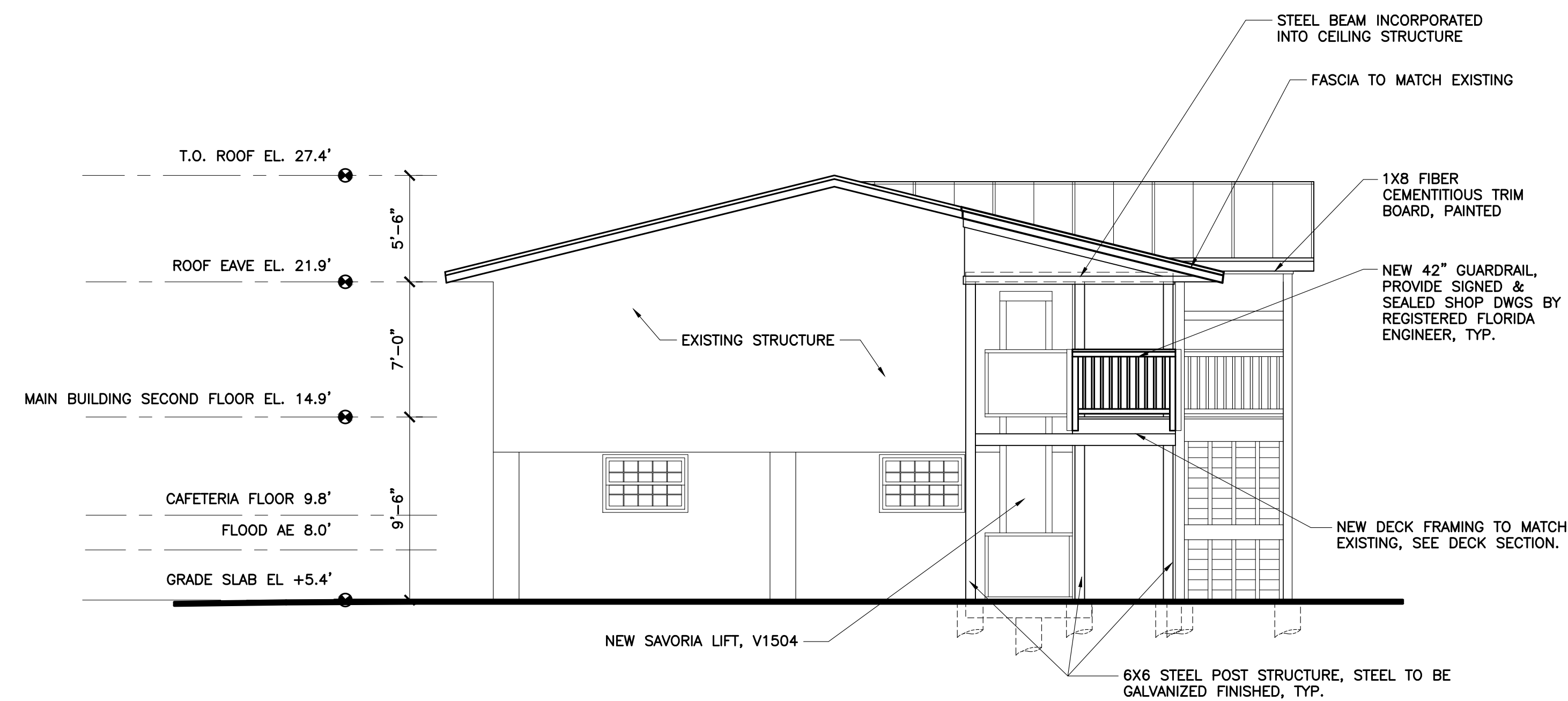

2
A-5

PROPOSED SIDE ELEVATION

SCALE: 3/16"=1'-0"

SEAL

DATE
01-28-2022 BID SET

REVISIONS

DRAWN BY
JFS

PROJECT NUMBER
2105

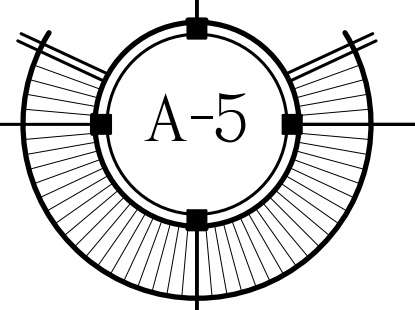

CANOPY NOTE:
CANOPY MEMBER SIZES AND DIMENSIONS ARE SHOWN AS
REFERENCE FOR CANOPY FABRICATOR. ALL FINAL CANOPY
MEMBER SIZES ARE SUBJECT TO FABRICATOR
REQUIREMENTS. DIMENSIONS GIVEN ARE TO BE TAKEN AS
MINIMUM MEMBER SIZES TO BE PROVIDED.

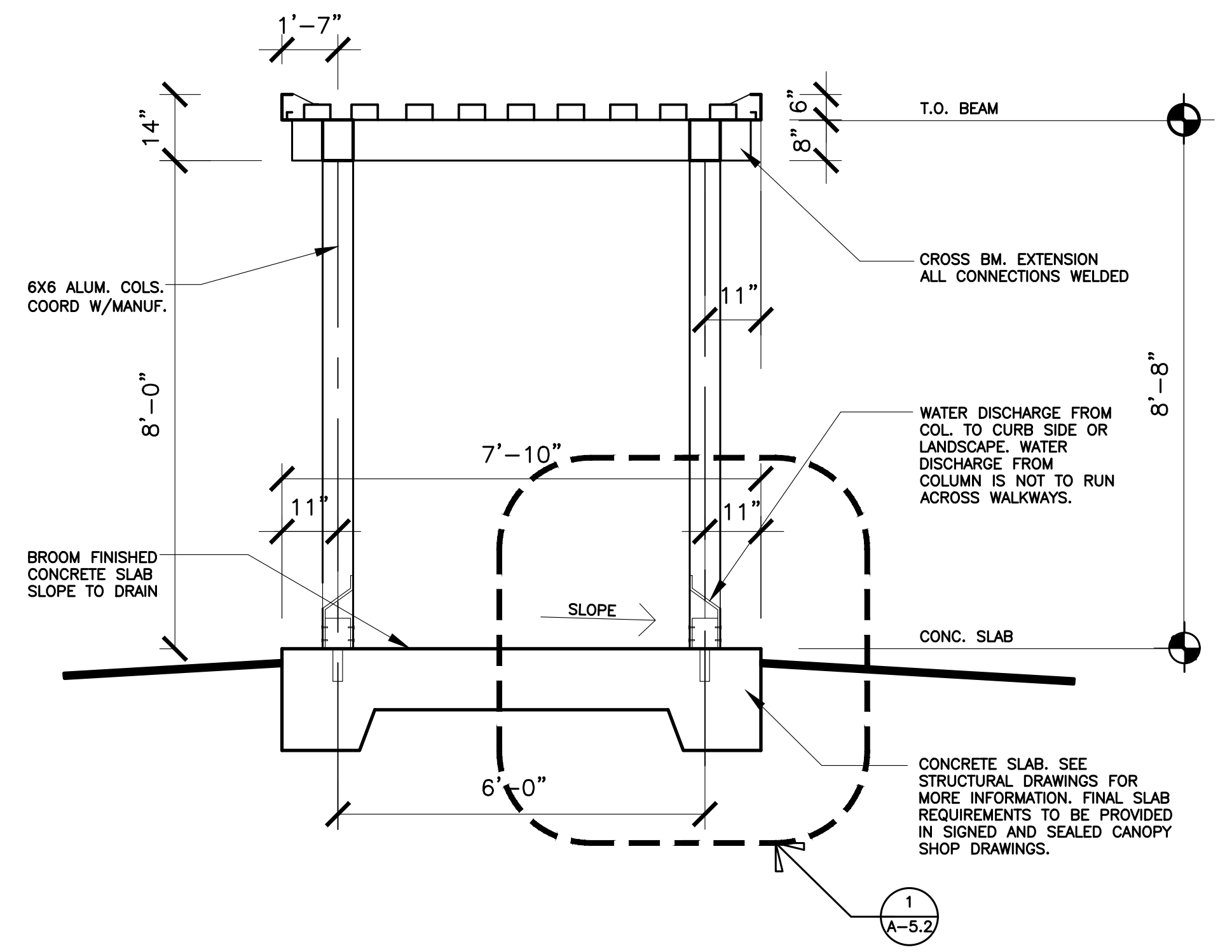

PROPOSED ROOF STRUCTURE SECTION AT SIDEWALK

SCALE: 1/2"=1'-0"

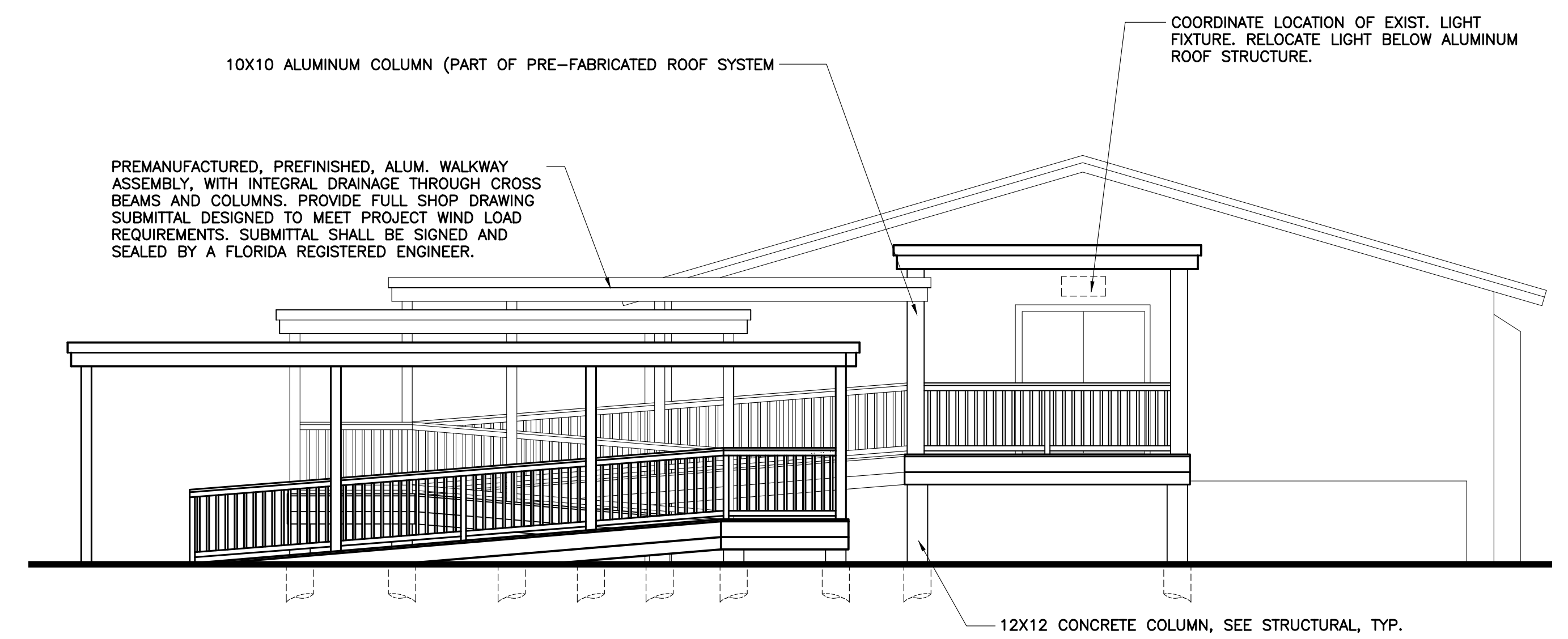

PROPOSED SIDE ELEVATION

SCALE: 3/16"=1'-0"

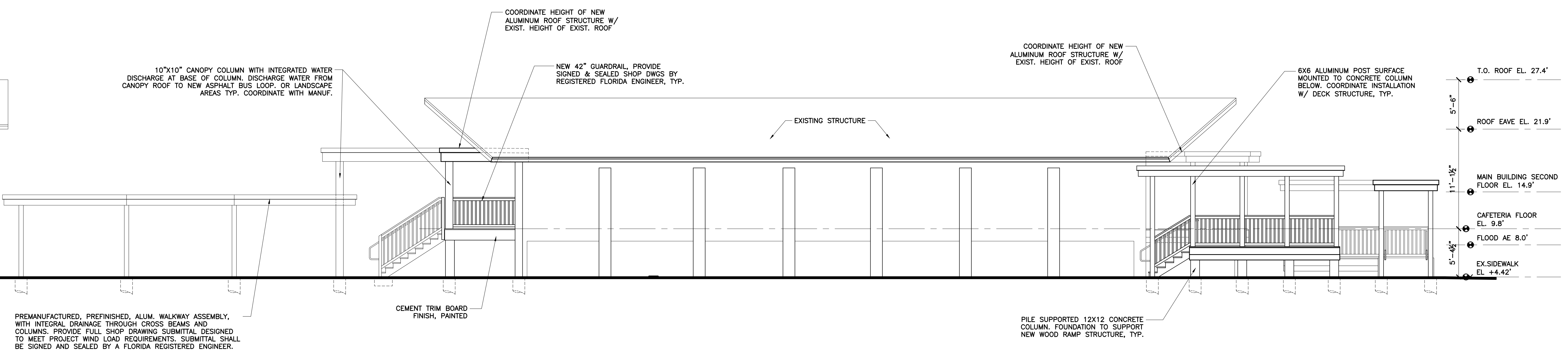

PROPOSED FRONT ELEVATION

SCALE: 3/16"=1'-0"

SEAL

DATE
01-28-2022 BID SET

REVISIONS

DRAWN BY
JFS

PROJECT NUMBER
2105

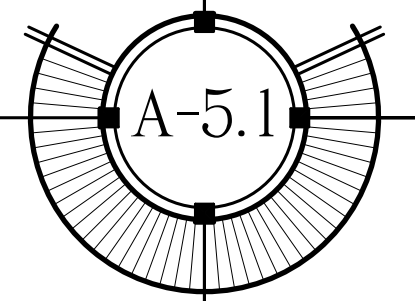

CANOPY NOTE:
CANOPY MEMBER SIZES AND DIMENSIONS ARE SHOWN AS
REFERENCE FOR CANOPY FABRICATOR. ALL FINAL CANOPY
MEMBER SIZES ARE SUBJECT TO FABRICATOR
REQUIREMENTS. DIMENSIONS GIVEN ARE TO BE TAKEN AS
MINIMUM MEMBER SIZES TO BE PROVIDED.

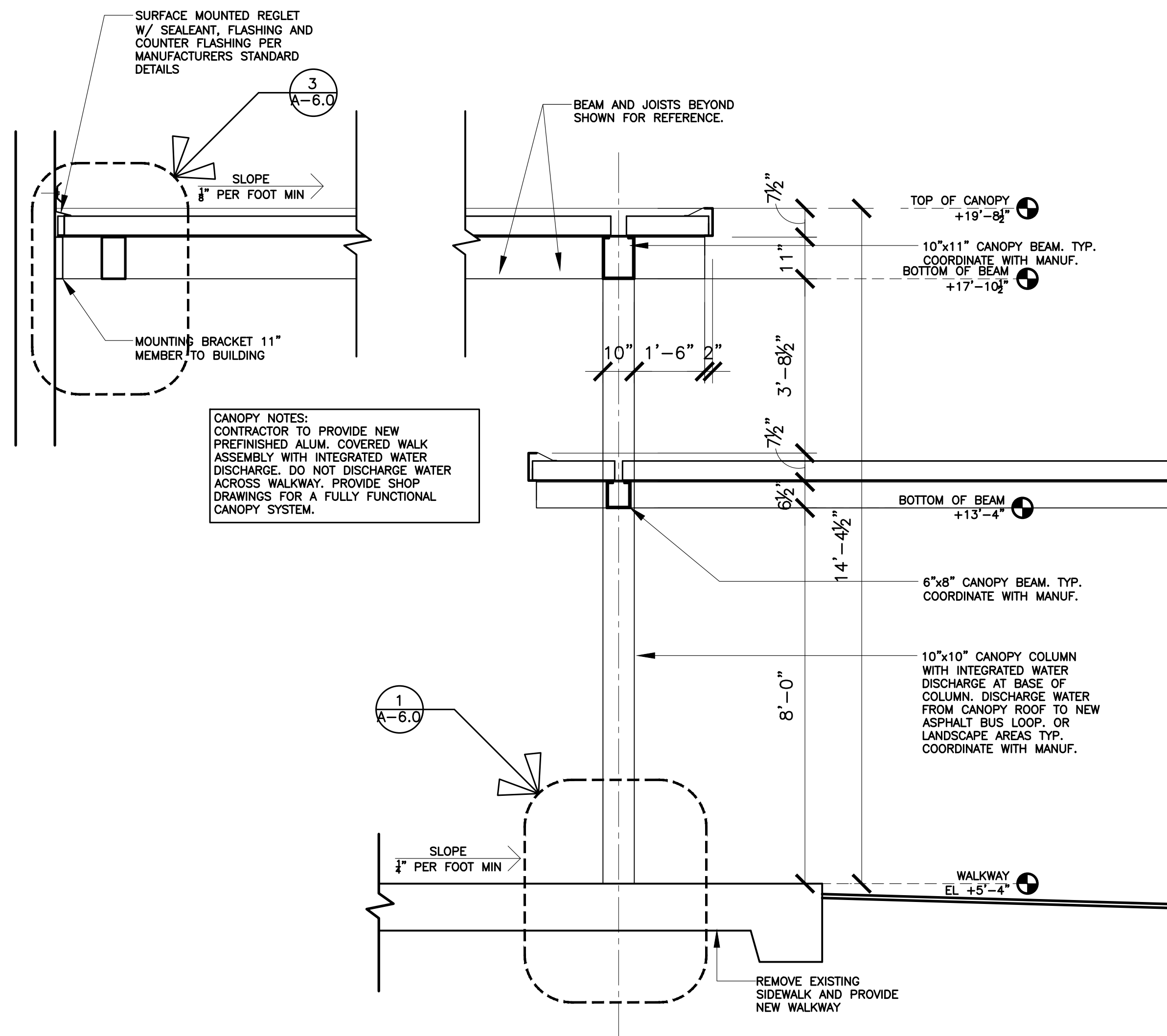

3
A-5.1
PROPOSED ROOF STRUCTURE SECTION AT SIDEWALK
SCALE: 1/2" = 1'-0"

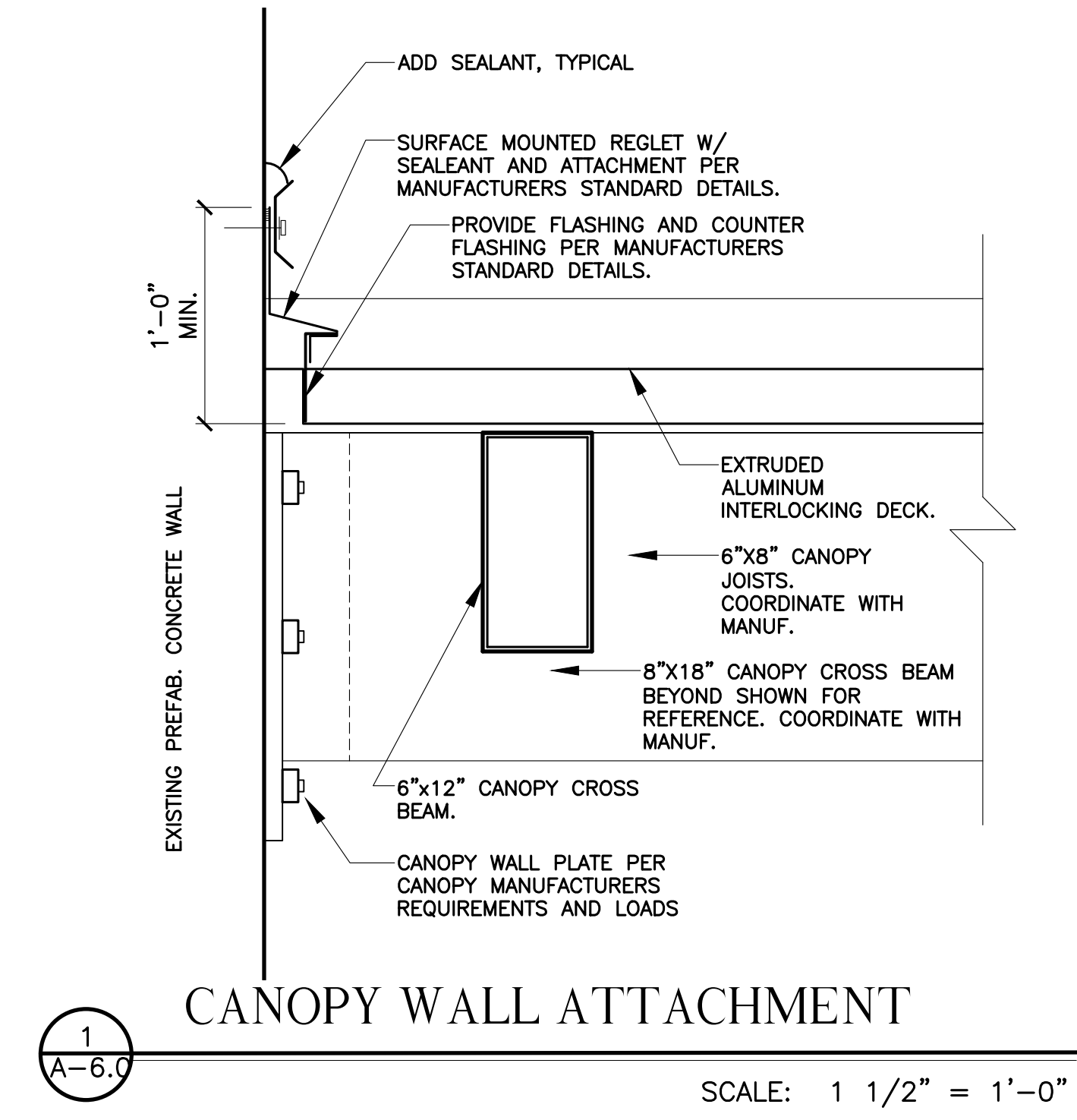

1
A-6.0
CANOPY WALL ATTACHMENT
SCALE: 1 1/2" = 1'-0"

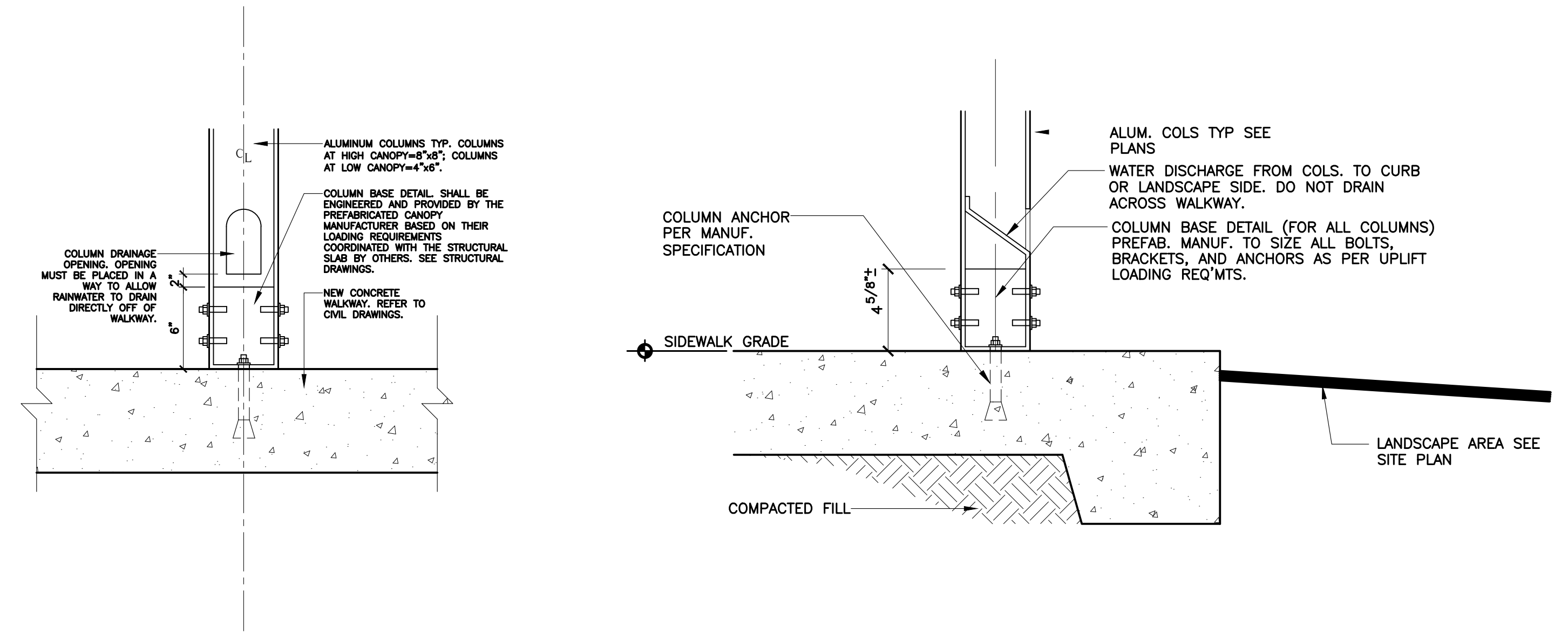

1
A-6.0
CANOPY BASE DETAILS
SCALE: 1" = 1'-0"

SEAL

DATE
01-28-2022 BID SET

REVISIONS

DRAWN BY
JFS

PROJECT NUMBER
2105

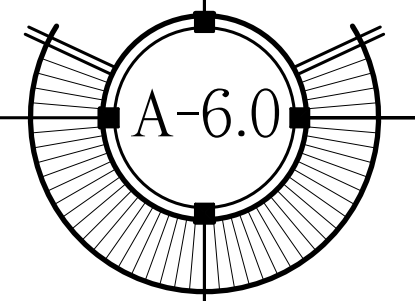

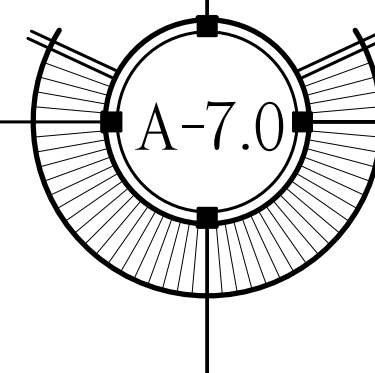

DIVISION 3 - CONCRETE (SEE STRUCTURAL DRAWINGS)

DIVISION 4 - MASONRY (NOT USED)

DIVISION 5 - METALS (ALSO SEE STRUCTURAL DRAWINGS)

05300 - Miscellaneous Metals, anchor bolts, nuts and washers shall be minimum 5/8 in. galvanized steel embedded minimum 7 in. into concrete and spaced maximum 2 feet c.c. Provide miscellaneous galvanized steel anchors, straps and hangers as required.

05320 - Manufactured Anchors and Straps shall be heavy duty galvanized metal G90, as manufactured by Simpson Strong Tie or equal. Item numbers shall be as identified on the drawings. In no event shall pier, sill, joist, plate, rafter or truss connections be made without anchorage devices for hurricane protection, unless specifically noted and address by other means. All truss anchors shall be designed, specified and supplied by Truss Fabricator.

05500 - Aluminum Fabrications

- A. All structural members shall conform to ASTM B221 specification- Aluminum Alloy Extrude Bar, Rod, Wire, Shape and Tube.
 - 1. Extruded aluminum: ASTM B221, Alloy 6063, Temper T-6.
 - 2. Sheet aluminum: ASTM B209 6063, Temper T-6.
- B. Provide Shop drawings showing layout, dimensions, profiles, spacing of components, and anchorage and installation details.
 - 1. Submit complete shop drawing for all structural components. Drawings shall include all shop and erection details, including dates, copes, connections, holes, bolts, shim plates and welds in structural steel. All welds, both shop and field, shall be indicated on the details on the shop drawings by standard welding symbols given in the AISC Manual.
 - 2. Contractor shall check shop drawings for field coordination of elevation and dimensions prior to submittal.
 - 3. All girders and handrails shall have welded connections of all members and have a shop applied powder coat finish (see paint spec's).
 - 4. All girders and handrails shall meet required codes for handicap compliance, structural compliance and size requirements.
- C. Provide aluminum caps for exposed open extruded aluminum sections and for attachment of components to posts.
- D. Aluminum shall receive polyester powder coating. Electrostatically applied colored polyester powder coating heat cured to chemically bond finish to metal substrate.
- E. Do not install bent, bowed, or otherwise damaged components. Remove damaged components from site and replace.

DIVISION 6 - WOOD AND PLASTICS (SEE STRUCTURAL DRAWINGS)

DIVISION 7 - THERMAL AND MOISTURE PROTECTION

07311 - Roofing Underlayment: At all sloped roofing installations, provide a high temperature, self adhesive, membrane underlayment such as Grace Ultra[®] as manufactured by Grace Construction Products, or equal. The underlayment is intended to function as secondary roof membrane over the decking. As such the membrane shall be continuous over all portions of the roof, with seams lapped a minimum of 3" and all penetrations for plumbing vents or other, sealed to the membrane. The membrane shall be self sealing for small penetrations such as roofing assembly fasteners to the deck (nails or screws). The underlayment membrane shall be provided for all sloped roofing assemblies including; V crimp, standing seam, shingles and ceramic tile, unless specifically noted, not to be installed. The contractor shall verify compatibility of roofing materials and anchorage devices with the membrane and coordinate with roofing manufacturers requirements. Note that standing seam aluminum roofing assemblies require an additional layer of 30# felt between the membrane and roof material.

07315 - Roofing Shop Drawings: All roofing assemblies require shop drawing submittals. The submittal shall include all components of the assembly including base sheets (if any), insulation if integral to the assembly, cover board, membranes and attachment, including edge conditions. The submittal shall include N.O.A. test data for the entire assembly, as a unit, or for each component used, including anchorage/attachment to its supporting substrate on down to the structural deck. Documentation that the project specific roofing assembly meets design wind loading is required. Documentation that the submittal of N.O.A. test data or by signed and sealed certification by a Florida Registered Engineer. Provide manufacturer's requirements and installation instructions for review.

07460 Fiber Cementitious Siding all exterior siding to be smooth finished 3/8" thick fiber cementitious lap siding with 5" exposed lap - "Hardiplank lap siding" as manufactured by James Hardie Building Products or equal. All siding shall be fastened according to the manufacturers recommendations in accordance with 180 MPH- Exposure C, ASCE-7. All siding and fasteners shall be for use in a coastal salt water environment and shall be installed over a membrane air and moisture barrier.

07600 - Roofing shall be 26 gauge galvanized "V" crimp metal roofing in longest sheets practicable. Finish shall be "galvalume" w/20 year finish warranty, coordinate flashing. Final color selection need to be coordinated with owner prior to ordering. Install over Grace Ultra Underlayment (high temperature) membrane over decking. Provide flashing and trim including preformed ridges and hip rolls and edge drip (all with Galvalume finish). Provide manufacturer's requirements, installation instructions and valid N.O.A. of system.

07620 - Flashing and sheet metal:

- A. This section to include: gavi, metal flashing and base flashing, stops, built-in metal valleys, gutters, scuppers and miscellaneous sheet metal accessories.
 - B. Material shall be zinc - coated steel, commercial quality ASTM A526 G90 hot-dip galvanized, 24 gage, except as noted otherwise. Coordinate finish with roofing finish (example: If roofing has galvalume finish use same finish on flashing).
 - C. Shapes shall match existing profiles of flashing and stops. Scuppers shall be fabricated in accordance with the details provide.
 - D. Shop-fabricate roof to the extent possible. Comply with details shown and applicable requirements of SMACNA "Architectural sheet metal manual" and material manufacturer recommendations.
- 07920 - Sealants**
- A. Silicized Acrylic Caulk - 25 years, paintable, non-staining, mildew resistant. For interior and exterior use, wood and masonry, as a filler for cracks voids and holes in preparation for paint or other finish - See existing wood preparation.
 - B. Polyseamseal all purpose adhesive caulk, paintable, non-staining, mildew resistant. For interior and exterior use as a filler and joint seal at tile, tub and counters.
 - C. Silicone Rubber Sealant - FSTT-S-001543, class A, one part non-sag low modulus silicone rubber sealant. For interior and exterior use in working joints where some movement is anticipated, wood, masonry, metal and glass. Provide backer rod depth control in all joints in excess of 1/4"
 - D. All interior architectural caulks and sealants to have a VOC limit of 250 g/L.

DIVISION 8 - DOOR AND WINDOWS (NOT USED)

DIVISION 9 - FINISHES

09220 - Stucco - Comply with ASTM C 926 for Portland cement base and finish coat mixes using Portland cement - ASTM C 150, masonry cement, lime - ASTM C 206, and sand ASTM C 897. Provide min. of three coat system w/scratch coat, brown coat, and finish coat. Finish coat shall consist of 1 part Portland cement, 1-1/2 to 2 parts lime, 3 parts sand. Additional base layers may be applied to achieve desired thickness over expanded metal galvanized lath. Provide control joints @ max. 12' to 16' vertically and horizontally, corners of wall penetrations (coordinate with architect), and at all substrate exp. joints or change of materials. Provide accessories of high impact poly vinyl chloride, to include stops casing beads, one and two piece control joints (two piece where movement is required) and corner bead. Expanded metal galvanized lath over a membrane air, moisture barrier shall be provided over all non masonry substrates. Stucco finish shall go on all concrete or masonry exterior surfaces unless otherwise noted to be skim coat stucco or just painted.

09900 - Painting - This section includes surface preparation, painting, and finishing of exposed interior and exterior items and surfaces. Surface preparation, priming, and finish coats specified in this section are in addition to shop priming and surface treatment specified under other sections.

- A. Paint exposed surfaces whether or not colors are designated in "schedules", except where a surface or material is specifically indicated not to be painted or is to remain natural. Where an item or surface is not specifically mentioned, paint the same as similar adjacent materials or surfaces. If color or finish is not designated, the architect will select from standard colors or finishes available.
- 1. Painting includes field painting exposed bare and covered pipes and ducts (including color coding), hangers, exposed steel and iron work, and primed metal surfaces of mechanical and electrical equipment.
 - 2. Painting is not required on prefinished items, finished metal surfaces, concealed surfaces, operating parts, and labels.
 - 3. Labels: do not paint over Underwriter's Laboratories, Factory Mutual or other code-required labels or equipment name, identification, performance rating, or nomenclature plates.
- B. Submit Data: Manufacturer's technical information, label analysis, and application instructions for each material proposed for use.
 - 1. List each material and cross-reference the specific coating and finish system and application. Identify each material by the manufacturer's catalog number and general classification.
 - 2. Samples for initial color selection in the form of manufacturer's color charts. The exterior will have three colors minimum, one being a special order color. The interior will have three colors minimum, one being a special order color.
 - C. Provide samples of each color and materials to be applied, with texture to simulate actual conditions, or representative samples of actual substrate. Define each separate coat, including fillers and primers. Use representative colors when preparing samples for review. Resubmit until required sheen, color, and texture are achieved.
 - 1. Provide a list of material and application for each coat of each sample. Label each sample as to location and application.

D. Paints and coating used on the interior of the building (i.e., inside of the weather proofing system and applied on - site) shall comply with the following criteria:

1. Architectural paints, coating and primers applied to interior walls and ceilings: Do not exceed the VOC content limits established in the Green Seal Standard GS-11, Paints, First Edition, May 20, 1993. Primers must meet the VOC limit for non-flat paint.
 - Flats: 50 g/L
 - Non-Flats: 100 g/L
2. Anti-corrosive and anti-rust paints applied to interior ferrous substrates: Do not exceed the VOC content limit of 250 g/L established in Green Seal Standard GS-03, Anti-corrosive Paints, Second Edition, January 7, 1997.
3. Clear wood finishes, floor coatings, stains, primers, and shellacs applied to interior elements must not exceed the VOC content limits established in South Coast Air Quality Management District (SCAQMD) Rule 1113, Architectural Coatings, rules in effect on January 1, 2004.

Provide paint as shown with all materials by Benjamin Moore or equal. Colors and finish shall be selected by owner.

Exterior wood:

Primer: Spot prime Knots & surrounding area w/ Bin Schulac (1 coat) Fresh start 100% Acrylic Superior Primer #046, VOC = 44 g/L
Finish:Mooregard 100% Acrylic Low Lustre House Paint # N103, VOC = 50 g/L (2 coats)

Exterior Fiber cementitious siding and trim:

Primer:Pre-primed
Finish:Mooregard 100% Acrylic Low Lustre House Paint #N103 or Moorfile 100% Acrylic Flat House Paint #N105 VOC = 50 g/L (2 coats)

Exterior stucco or Masonry (to be painted)

Primer:Super Spec Masonry Interior/Exterior 100% Acrylic Masonry Sealer #N068 VOC = 81 g/L. Use Moore's High Build Acrylic Masonry Primer #N068 VOC = 97 g/L for very porous conditions
Finish:(2 coats) Regal select Flat Finish #N400 or Regal select Soft Gloss Finish #N402 VOC = 50 g/L

Porch and Stair Treatments (Wood)

Primer:Alkyd Urethane reinforced
Porch floor enamel (thin first coat on bare wood)
Add skidtex to prime coat
Finish:Alkyd urethane reinforced porch floor enamel

Galvanized metal and Aluminum (Non Ferrous Metal)

Clean surfaces with Super Spec HP oil and grease emulsifier (P83) to remove contaminants
Primer:One coat Super Spec HP D.T.M. Acrylic Semi-Gloss #WP29 VOC = 45 g/L
Finish:One coat Super Spec HP D.T.M. Acrylic Semi-Gloss #WP29 VOC = 45 g/L

Structural Steel and Iron (Ferrous Metal)

Primer and Finish...2 Coats Super Spec HP D.T.M. Acrylic Semi-Gloss #WP29, VOC = 45 g/L

Powder Coat Paint Finish System (Applied in Shop)

1. Electrostatically applied colored polyester powder coating heat cured to chemically bond finish to metal substrate.
2. Minimum hardness measured in accordance with ASTM D3363: 2H.
3. Direct impact resistance tested in accordance with ASTM D2794. Withstand 160 inch-pounds.
4. Salt spray resistance tested in accordance with ASTM B117: No undercutting, rusting, or blistering after 500 hours in 5 percent salt spray at 95 degrees F and 95 percent relative humidity and after 1000 hours less than [3/16 inch] [5 mm] undercutting.
5. Weatherability tested in accordance with ASTM D822: No film failure and 88 percent gloss retention after 1 year exposure in South Florida with test panels tilted at 45 degrees.
6. Firm with manufacturing and delivery capacity required for the project, shall have successfully completed at least ten projects within the past five years, utilizing finish systems, and techniques as herein specified.
7. Supplier must own and operate its own Painting and Finishing facility to assure single source responsibility and quality control.
8. All materials shall be protected during finishing, shipment, site storage and erection to prevent damage to the finished work from other trades. Store materials inside a well-ventilated area, away from un cured concrete and masonry, and protected from the weather, moisture, soiling, abrasion, extreme temperatures, and humidity.
9. Clean all surfaces following installation. If necessary use only a mild soap or detergent solution such as TSP-90 or Ivory with a soft cloth to remove dirt and hand prints. Black handling marks can be removed using a mixture of isopropyl alcohol and an abrasive cleanser like Comet. Replace units having scratches, abrasions, or other defects, with unblemished materials.

09940 - Existing wood preparation: Contractor to remove and replace all rotted or damaged wood to match existing (use pressure treated wood). Splice in new boards as inconspicuously as possible and stagger joints as required. Scrape all loose paint of existing wood surfaces, sand smooth prior to prime coat paint. (see paint specification). After prime coat, caulk all seams, joints and holes as required prior to finish coats (see sealant specifications).

DIVISION 10 - SPECIALTIES (NOT USED)

DIVISION 11 - EQUIPMENT (NOT USED)

DIVISION 12 - 13 & 14 (NOT USED)

DIVISION 15 - MECHANICAL (NOT USED)

DIVISION 16 - ELECTRICAL (SEE ELECTRICAL DRAWINGS)

01800 - GENERAL REQUIREMENTS

Project Description The Contractor shall furnish all labor and materials required and necessary to provide a complete habitable, weatherproof, safe and secure finish building, suitable for human occupancy in accordance with Specifications, Drawing and Project Documents.
The Florida Building Code 2020 Edition, as amended by Governing Local Ordinances and requirements of the State of Florida "Coastal Zone Protection Act", together with applicable requirements of governing public agencies and the following listed codes shall apply to this project.

Florida Existing Building Code, 2020 Edition

Florida Building Code-Accessibility, 2020 Edition

Florida Building Code-Energy Conservation, 2020 Edition

National Electric Code 2017 Edition

FEMA, Coordinate all building items required to be above flood elevation for project and other FEMA regulations that apply to the project.

Lead paint safety requirements: The contractor is required to use lead safe work practices for buildings built before 1978. All lead paint shall be removed or covered as per EPA and other code requirements. Contractor to coordinate with owner for investigative methods, removal solutions and costs.

Contractor shall visit the site to become familiar with existing conditions and requirements of construction prior to bidding.

Contractor shall complete new work in conformance with these drawings. Notify Architect if conflicts appear or are uncovered during the progress of the work prior to any field modifications or construction. Deviations from permitted drawings without Architects prior written approval shall be at the Contractors responsibility. Contractor is to verify all dimensions of project prior to proceeding with construction. Notify architect of any conflicts or problems so solutions can be achieved prior to construction. In event of conflict between drawings and specifications the most stringent requirements shall apply. Verification shall include, but not limited to, coordination of site work, existing conditions, buildings and utilities. Verify that building's architectural plan and foundation plan dimensions and elevations work on the actual site prior to starting any construction. Notify architect of any conflicts so solution can be worked out prior to construction.

Contractor shall provide all subcontractors complete set of drawings, including drawings from other disciplines. Change orders will not be allowed because a subcontractor only looked at drawings for his discipline and not other disciplines. Contractor must review all drawings and notify Architect of any conflicts. If a conflict arises assume worst case scenario for bidding and or Construction (or notify Architect for clarification prior to bidding). General Contractor is responsible for reviewing the complete set of drawings and specifications and assuring that his and his subcontractors bids include complete work and systems (free of conflict with other contractors and subcontractors).

Contractor and subcontractor shall follow industry standards for each discipline. Drawings do not show every condition, fastener, etc. If something is not detailed, follow industry standards. Provide complete functioning systems.

Contractor shall coordinate all final floor finishes and thicknesses and adjust floor levels as required to maintain desired or required level changes (if any). This shall be done prior to building the floor. Coordinate with Architect and Owner as required.

Contractor needs to coordinate final color selections with owner and architect prior to ordering items.

Factory finished items such as roofing, windows and doors need color and finish selections verified in writing by owner and architect prior to ordering.

Allowance items, if any shall be listed in writing by the Owner/Architect prior to bidding.

General Notes:

- A. Engineer's approval must be secured for all structural substitutions.
- B. Verify all openings through floors, roof and walls with mechanical and electrical contractors. Verification of locations, sizes, lintel and required connections are contractor's complete responsibility.
- C. The MEP plans and drawings are diagrammatic of the work to be performed and may not show every item and/or detail. Some components may be shown outside the work area for clarity. The work shall be executed in a manner to avoid conflicts with other trades and other elements of construction. All deviations from the plans shall be approved by the owner and/or owner's representative before being installed. The contractor shall not willfully install any aspect of the mechanical, electrical, or plumbing systems as shown on the plans and drawings when it is obvious in the field that obstructions or discrepancies exist that might not have been known during the design of the systems, in the event that notification of the conflict is not approved by the owner's representative, the contractor will assume full responsibility for all revisions.
- D. Prior to installation of mechanical and electrical equipment or other items to be attached to the structure, engineer's approval of connections and supports shall be obtained. Unless specifically detailed on architectural and structural drawings, respective sub-contractor shall furnish all hangers, connections, etc., required for installation of his items.
- E. Provide all embedded items in structure as noted on architectural, mechanical, electrical as well as structural drawings. Miscellaneous embedded items and anchor bolts shall be furnished by steel supplier and installed by concrete contractor.
- F. Contractor to verify all dimensions before proceeding with any new work, including layout of the entire project on site for verification of setbacks, elevations and location of existing trees.
- G. Provide temporary bracing and precautions necessary to withstand all construction and/or wind loads until all field connections are completed and shear walls and decks are in place. All shoring is the responsibility of the contractor including use of a specialty engineer if required.
- H. Submit shop and erection drawings for all items required by the drawing or elsewhere in the specifications for written approval. The manufacturing or fabrication of any items prior to written approval of shop drawings will be entirely at the risk of the contractor. All references to standards to be of the latest issue applicable.
- I. This project is in a coastal salt water environment. Contractor shall consider this in selections of materials used in the exterior and non-air conditioned areas. All materials shall be salt resistant.
- J. Manufactured assemblies, such as roofing, soffits, panels, storefronts, doors, windows and other external assemblies incorporated into the project shall require detailed shop drawing submittals. Miami Dade N.O.A'S or Florida product approvals providing tested assembly installation details and windload compliance are required. Manufacturers recommendations and requirements (including warranty requirements) shall be incorporated along with the latest industry standards and best practices. All final color selections or finishes shall be coordinated and verified with the owner and architect prior to ordering (typical).
- K. Waterproofing, vapor barriers, waterstop, air seals,, etc. shall be as indicated in the specifications and as per manufacturer and industry standards.
- L. Contractor to provide all required fire blocking as required by Code.
- M. Contractor to take all precautions to prevent mold from growing in or on the building. Do not use materials that have mold on them for construction, close up building each night to keep water out, do not install AC ducts until building is dried in and take all other possible efforts to prevent mold from growing.
- N. All stairs to be a minimum of 44" wide (handrails are allowed to intrude), except single family stairs which can be 36" wide. Provide 42" high minimum guardrails (single family can be 36"), maintain 6'-8" clear height for stairs and all other areas.
- O. All required exit stairs serving handicapped accessible areas shall be provided with an area of rescue assistance and shall be 48" clear between handrails.
- P. All penetrations of fire rated construction shall be treated with dampers, seals, collars, etc., see section 09260 and 15100.
- Q. When working within occupied or partially occupied buildings it is the contractors responsibility to provide safe access and to maintain in operation all features of existing life safety systems including alarms, detectors, lighting and exit ways throughout the course of construction.
- R. If in the event of conflicting, or overlapping requirements in any area of the proposed documents, technical specifications, or drawings, the most stringent condition shall be proposed and constructed.

DIVISION 2 - SITE AND CIVIL WORK

02110 and 02200 - Clearing/Grading/Compacting & Fill Placement. Remove existing topsoil and organic material within building areas. Exposed near-surface soils shall be compacted to densities equivalent to 95% Proctor density (ASTM D1557). The upper one foot of soil beneath slabs shall be compacted to 98% Proctor density. Fill shall be a relatively clean sand or crushed limestone (max. particle size of 3 in.). Grade as required (as shown on plan or to drain away from buildings).

- 02150 - Tree removal (if required)**
- A. Trees indicated on the drawings for removal shall be cut, stump and root system shall be removed.
- B. Resulting holes shall be filled and leveled with appropriate soil.
- C. All debris shall be removed from the site and disposed of in a proper manner.
- D. Care shall be taken to avoid any damage to adjacent trees and plant material.
- E. Provide construction barricades for protection of trees within 10'-0" of building lines.

02250 - Demolition shall include the removal of all items as indicated on the drawings, as well as incidental items necessary for new work to progress. All work shall be done in a workman like manner with minimal disturbance to existing to remain; see structural specifications for temporary shoring and bracing. All unwanted material to be removed from the site and properly disposed of. Unless noted otherwise, patch all areas to remain to match existing in areas damaged by demolition.

02350 - Foundations (SEE STRUCTURAL DRAWINGS)

02351 - Termite Control. Provide soil treatment for termite control at slabs on grade including foundations and slab penetrations, if any. Formulate and apply termiticides, and label with a federal registration number, to comply with EPA regulations and authorities having jurisdiction. Use only soil treatment solutions not harmful to plants. Apply at label volume and rate per EPA- registered label with application by a licensed pest control operator. Provide a soil treatment application report for owners record and use.

02500 - Walks - walkways shall be light broom finish concrete unless noted. Min. 4" thickness w/ 6x6 WWP 10T10. Prepared base ± 6" crushed limestone compacted to 95% proctor.

02855 - Underground Utilities - Contractor shall include in his work all underground (and above) utility work for all systems to make a complete system from buildings to street hook-ups as required to complete the job.

MISCELLANEOUS

- THESE ABBREVIATED DRAWING SPECIFICATIONS ARE WRITTEN TO MATCH THE BOOK SPECIFICATIONS. IF THERE ARE ANY ITEMS THAT DO NOT CORRESPOND EXACTLY AS WRITTEN, THE MORE STRINGENT WILL TAKE PRECEDENCE.
- THE STRUCTURAL SYSTEM IS UNSTABLE UNTIL ALL CONNECTIONS HAVE BEEN MADE AND ALL CONCRETE HAS REACHED ITS MINIMUM DESIGN STRENGTH, AS SHOWN IN THE STRUCTURAL DOCUMENTS.
- CONTRACTOR IS RESPONSIBLE FOR MEANS AND METHODS OF CONSTRUCTION TO ENSURE THE SAFETY OF THE BUILDING UNTIL STRUCTURAL SYSTEM IS COMPLETED. THIS INCLUDES, BUT IS NOT LIMITED TO, THE ADDITION OF WHATEVER TEMPORARY BRACING, SHORING, GUYS OR TIEDOWNS THAT MAY BE NECESSARY. SUCH MATERIAL SHALL BE REMOVED AND SHALL REMAIN THE PROPERTY OF THE CONTRACTOR AFTER COMPLETION OF THE PROJECT.
- CONTRACTOR TO SUPPORT, BRACE AND SECURE EXISTING STRUCTURE AS REQUIRED. CONTRACTOR IS SOLELY RESPONSIBLE FOR THE SAFETY OF THE BUILDING DURING CONSTRUCTION.
- APPLICABLE BUILDING CODE: 7TH EDITION (2020) FLORIDA BUILDING CODE.
- GRAVITY DESIGN LOADS:

AREA	SUPERIMPOSED LIVE LOAD	TOTAL DEAD LOAD
ROOF	20 PSF	35 PSF
STAIRS	100 PSF	25 PSF
+ RAMPS		
- WIND DESIGN CRITERIA:

ULTIMATE WIND SPEED: $V_{ULT} = 182$ MPH (3 SECOND GUST)
EQUIVALENT NOMINAL BASIC WIND SPEED $V_{ASD} = 141$ MPH (3 SECOND GUST)
RISK CATEGORY = II
EXPOSURE CATEGORY = D
ENCLOSED BUILDING INTERNAL PRESSURE COEFFICIENT, $GCP_i = +/-0.18$
WIND BORNE DEBRIS REGION
- ALL MATERIALS AND WORKMANSHIP SHALL BE IN ACCORDANCE WITH THE REFERENCED BUILDING CODE.
- COORDINATE ALL DIMENSIONS AND ELEVATIONS WITH THE ARCHITECTURAL DRAWINGS. DO NOT SCALE DRAWINGS.
- CONTACT ENGINEER WITH ANY QUESTIONS OR DISCREPANCIES FOUND ON DRAWINGS.
- BUILDING EXPANSION JOINTS (EJ), WHERE SHOWN, WILL EXPAND AND CONTRACT OVER THE LIFE OF THE BUILDING. JOINT SEALANTS AND COVERS MUST ACCOMMODATE THIS MOVEMENT.
- SECTIONS AND DETAILS ARE REFERENCED IN TYPICAL LOCATIONS BUT ALSO APPLY TO ALL OTHER SIMILAR CONDITIONS.
- CONTRACTOR TO VERIFY ALL EXISTING DIMENSIONS, ELEVATIONS, AND CONDITIONS PRIOR TO BEGINNING CONSTRUCTION.
- SUBMIT SHOP DRAWINGS AS REQUIRED HEREIN. ALLOW FOR TWO WEEKS REVIEW TIME AFTER RECEIPT OF SUBMITTALS BY THIS FIRM. ALL SUBMITTALS SHALL BE CHECKED AND SIGNED BY THE GENERAL CONTRACTOR AND SIGNED/SEALED BY THE DELEGATED ENGINEER, WHERE SPECIFIED HEREIN.
- CONTRACTOR SHALL NOT BE RELIEVED FROM RESPONSIBILITY FOR ERRORS OR OMISSIONS IN SHOP DRAWINGS OR MIX DESIGNS BY THE ENGINEER'S REVIEW THEREOF.
- ANY CHANGES TO THE STRUCTURE SHALL HAVE BEEN REVIEWED AND APPROVED IN WRITING BY THE ENGINEER PRIOR TO COMMENCING WORK ON ITEMS AFFECTED.
- CONTRACTOR SHALL NOTIFY THIS OFFICE WHEN THE STRUCTURAL SYSTEM IS SUBSTANTIALLY COMPLETED, AND BEFORE SHEATHING, CEILINGS, OR ROOFING IS INSTALLED.

HAND RAILS

- AN ENGINEER REGISTERED IN THE STATE OF FLORIDA SHALL DESIGN RAILING SYSTEM AND CONNECTION OF IT TO THIS STRUCTURE.
- SUBMIT SHOP DRAWINGS BEARING THE EMBOSSED SEAL AND THE SIGNATURE OF THE ENGINEER FOR REVIEW PRIOR TO FABRICATION.
- THE CONFIGURATION OF THE RAILING SYSTEM SHALL BE AS SHOWN ON THE ARCHITECTURAL DRAWINGS.
- RAILING SYSTEM AND CONNECTIONS SHALL BE DESIGNED FOR APPLICABLE LOADS AS INDICATED ON THE PLANS AND IN THE BUILDING CODE. THE LOADS SHALL BE CLEARLY INDICATED ON SHOP DRAWINGS.
- SHOP DRAWINGS SHALL SHOW AND SPECIFY CONNECTIONS UTILIZED WITHIN THE RAILING SYSTEM AS WELL AS CONNECTIONS TO AND LOADS IMPOSED UPON THE STRUCTURAL SYSTEM SHOWN ON THESE PLANS.

EXISTING BUILDINGS

INFORMATION ON THE EXISTING BUILDING, SHOWN ON THESE PLANS, IS OBTAINED FROM PLANS BY WILLIAM P. HORN ARCHITECT, DATED NOVEMBER 11, 2021. EXISTING INFORMATION DOES NOT NECESSARILY REFLECT AS-BUILT CONDITIONS. THE CONTRACTOR SHALL VERIFY ALL INFORMATION SHOWN ON THESE PLANS AND NOTIFY THE ENGINEER OF ANY VARIATION.

GEOTECHNICAL INVESTIGATION

- A SUBSURFACE INVESTIGATION SHALL BE COMPLETED AT THE SITE BY A LICENSED GEOTECHNICAL ENGINEER PRIOR TO BEGINNING EARTHWORK OPERATIONS.

- THE GEOTECHNICAL ENGINEER SHALL DETERMINE THE METHOD OF TESTING. (BORINGS, PROBES, HAND AUGERS, ETC.)
- A SIGNED/SEALED SOILS REPORT SHALL BE SUBMITTED TO THE A/E, WHICH SHALL INCLUDE SITE PREPARATION PROCEDURE, FOUNDATION DESIGN RECOMMENDATIONS, AND CONSTRUCTION TESTING REQUIREMENTS.
- SINCE FOUNDATION DESIGN INFORMATION WAS NOT AVAILABLE AT THE TIME THESE DRAWINGS WERE PREPARED, THE FOLLOWING ASSUMPTIONS WERE MADE:
 - MAXIMUM BEARING PRESSURE = 2,000 PSF
 - MAXIMUM SETTLEMENT = 3/4"
 - MAXIMUM DIFFERENTIAL SETTLEMENT = 1/2"
- THE FOUNDATION DESIGN IS SUBJECT TO CHANGE PENDING THE RESULTS OF THE GEOTECHNICAL INVESTIGATION AND PENNONI'S REVIEW OF THE SOILS REPORT.

AUGERCAST PILING

- DIAMETER = 14 INCHES
SERVICE LOAD CAPACITIES:
DOWNWARD = 35 TONS
UPLIFT = 9 TONS
LATERAL = 1.5 TONS
- AUGERCAST PILES SHALL BE FABRICATED BY ROTATING A CONTINUOUS FLIGHT HOLLOW SHAFT AUGER INTO THE GROUND TO AN ESTIMATED DEPTH OF 8-11 FEET BELOW EXISTING GRADE.
- HIGH-STRENGTH GROUT SHALL BE PUMPED AS THE AUGER IS WITHDRAWN TO FILL THE HOLE, PREVENTING HOLE COLLAPSE AND TO CAUSE THE LATERAL PENETRATION OF THE GROUT INTO SOFT OR POROUS ZONES OF THE SURROUNDING SOIL.
- WHILE WITHDRAWING THE AUGER, A POSITIVE HEAD OF AT LEAST SEVEN FEET OF GROUT SHALL BE MAINTAINED ABOVE THE TIP OF THE AUGER TO ASSURE THAT THE PILE IS PROPERLY AND CONTINUOUSLY FORMED. IN ALL CASES, PILES SHALL BE FORMED WHILE THE AUGER IS INITIALLY BEING WITHDRAWN.
- IF REINFORCEMENT IS REQUIRED, IT SHALL BE PLACED WHILE THE GROUT IS STILL FLUID. SEE DRAWINGS FOR PILE REINFORCEMENT.
- THE GROUT USED TO FILL THE HOLES SHALL CONSIST OF A MIXTURE OF PORTLAND CEMENT, MINERAL FILLER, FLUIDIFIER, SAND AND WATER SO PROPORTIONED AND MIXED AS TO PROVIDE A GROUT CAPABLE OF MAINTAINING THE SOLIDS IN SUSPENSION WITHOUT APPRECIABLE WATER GAIN, YET WHICH MAY BE PUMPED WITHOUT DIFFICULTY AND WHICH WILL LATERALLY PENETRATE AND FILL ANY VOIDS IN THE FOUNDATION MATERIAL.
- THE MATERIALS SHALL BE SO PROPORTIONED AS TO PROVIDE A HARDENED GROUT HAVING AN ULTIMATE COMPRESSIVE STRENGTH OF 4000 PSI AT 28 DAYS.
- THE GROUT MIX SHALL BE TESTED BY MAKING ONE SET OF CYLINDERS FOR EACH DAY DURING WHICH AUGERCAST PILES ARE PLACED. A SET OF CYLINDERS SHALL CONSIST OF TWO CYLINDERS TO BE TESTED AT 7 DAYS AND TWO CYLINDERS TO BE TESTED AT 28 DAYS. TEST CYLINDERS SHALL BE MADE AND TESTED IN ACCORDANCE WITH ASTM D_109.
- ONLY APPROVED PUMPING AND CONTINUOUS MIXING EQUIPMENT SHALL BE USED IN THE PREPARATION AND HANDLING OF THE GROUT. ALL OIL OR OTHER RUST INHIBITORS SHALL BE REMOVED FROM MIXING DRUMS AND PRESSURE GROUT PUMPS.
- THE GROUT PUMP SHALL BE A POSITIVE DISPLACEMENT PISTON TYPE PUMP CAPABLE OF DEVELOPING PRESSURES AT THE PUMP UP TO 350 PSI. THE PUMP SHALL BE EQUIPPED WITH A SUITABLE GAGE TO PERMIT VERIFICATION OF PUMPING PRESSURES.
- THE MINIMUM VOLUME OF GROUT PLACED IN THE HOLE SHALL EQUAL THE VOLUME OF THE AUGERED HOLE. ALL MATERIALS SHALL BE SUCH AS TO PRODUCE A HOMOGENEOUS GROUT OF THE DESIRED CONSISTENCY. IF THERE IS A LAPSE IN THE OPERATION, THE GROUT SHALL BE RE-CIRCULATED THROUGH THE PUMP.
- PILE CENTERS SHALL BE LOCATED TO AN ACCURACY OF PLUS OR MINUS THREE INCHES. PILES SHALL BE INSTALLED PLUMB WITHIN A TOLERANCE OF ONE INCH IN TEN FEET.
- ADJACENT PILES SHALL NOT BE PLACED CLOSER THAN 3.5 FEET CENTER TO CENTER UNTIL THE GROUT IN THE PILES HAS SET FOR 24 HOURS.
- ONE QUICK LOAD PILE LOAD TEST WILL BE PERFORMED IN ACCORDANCE WITH ASTM D_1143. THE CONTRACTOR WILL FURNISH REACTION BEAM, REACTION PILES, AND OTHER PERSONNEL AND RIGGING NECESSARY TO PERFORM THE TESTS. THE TESTS SHALL BE MONITORED BY A TESTING LABORATORY. PRODUCTION PILES SHALL NOT BE TESTED.
- WHERE THE PILE CUTOFF IS NEAR THE SURFACE OR ABOVE THE BOTTOM OF THE EXCAVATION, METAL SLEEVES OF THE PROPER DIAMETER SHALL BE PLACED AROUND THE PILE TOPS.
- INSTALLATION OF THE AUGERCAST PILES SHALL BE CONTINUOUSLY INSPECTED BY A QUALIFIED TESTING LABORATORY.
- BID SHALL BE FOR A LUMP SUM AMOUNT BASED ON THE NUMBER OF PILES, ESTIMATED LENGTH AND THE TOTAL ESTIMATED FOOTAGE AS SHOWN IN THE PLANS AND/OR SPECIFICATIONS.
- SEPARATE UNIT PRICES SHALL BE QUOTED TO COVER EACH OF THE FOLLOWING:
 - A UNIT PRICE PER FOOT OF PILE FOR ADDITIONAL FOOTAGE IN EXCESS OF THE TOTAL PILE LENGTH BID.
 - A UNIT PRICE PER FOOT OF PILE CREDIT FOR FOOTAGE LESS THAN THE TOTAL PILE LENGTH BID.
- LOAD TESTS SHALL BE BID AT A UNIT PRICE FOR EACH TEST.
- NO PAYMENT SHALL BE MADE FOR MISPLACED, FAULTY OR OTHERWISE NON-ACCEPTABLE PILES AS DEFINED BY THE ENGINEER.
- STEEL SHALL CONFORM TO:

DRILL-IN BOLTS, SCREWS AND DOWELS

- ADHESIVE DOWELING RODS/BOLTS SHALL BE CARBON STEEL THREADED ROD CONFORMING TO ISO 898 5.8 WITH A MINIMUM TENSILE STRENGTH OF 72.5 KSI (500MPA) AND A MINIMUM YIELD OF 58 KSI (400MPA). THREADED RODS WITH NUTS AND WASHERS INSTALLED IN ACCORDANCE WITH MANUFACTURER'S INSTRUCTIONS.
- ANCHORING ADHESIVE SHALL BE A TWO-COMPONENT SYSTEM SUPPLIED IN MANUFACTURER'S STANDARD SIDE-BY-SIDE FOIL PACKAGE AND DISPENSED THROUGH A STATIC-MIXING NOZZLE SUPPLIED BY THE MANUFACTURER. ADHESIVE SHALL BE TESTED AND APPROVED TO MEET THE MINIMUM REQUIREMENTS OF ACI 355.4 FOR CRACKED AND UNCRACKED CONCRETE RECOGNITION. PROVIDE HILTI HY 200 SAFE SET (ESR 3187) OR RE 500 V3 (ESR 3814) ANCHORS BY HILTI OR EQUAL (E.G. SIMPSON SET-XP, ATC ULTRABOND 365CC) UNLESS SPECIFIED OTHERWISE IN THE STRUCTURAL DOCUMENT.
- DRILL-IN REBAR DOWELS SHALL BE SET USING A TWO-PART ADHESIVE AS DESCRIBED ABOVE.
- EXPANSION BOLTS SHALL HAVE CARBON STEEL ANCHOR BODY AND NUT AND WASHER SHALL BE ELECTROPLATED ZINC COATING CONFORMING TO ASTM B633 TO A MINIMUM OF 5MM. THE STAINLESS STEEL ANCHOR BODY, NUT AND WASHER, AND EXPANSION SLEEVE SHALL CONFORM TO TYPE 316 STAINLESS STEEL. EXPANSION ANCHORS SHALL MEET THE MINIMUM REQUIREMENTS OF ACI 355.2 FOR CRACKED AND UNCRACKED CONCRETE. INSTALL IN ACCORDANCE WITH MANUFACTURER'S INSTRUCTIONS.
- SCREWS SHALL HAVE A BODY MADE OF CARBON STEEL AND SHALL BE HEAT TREATED AND SHALL HAVE 8MM ZINC COATING IN ACCORDANCE WITH EN ISO 4042. PROVIDE HUS EZ (ESR 3027) SCREWS BY HILTI OR EQUAL.

STRUCTURAL STEEL

- STRUCTURAL STEEL SHALL CONFORM TO THE AISC "SPECIFICATION FOR BUILDINGS", LATEST EDITION.
- WELDED CONNECTIONS SHALL CONFORM TO THE LATEST REVISED CODE OF THE AMERICAN WELDING SOCIETY, AWS D1.1. ALL WELDING SHALL BE PERFORMED USING E70XX, LOW HYDROGEN ELECTRODES. ELECTRODES ARE TO BE PROTECTED FROM MOISTURE.
- CONNECTIONS TO BE DOUBLE ANGLE FRAMED BEAM CONNECTION PER AISC UNLESS NOTED OTHERWISE. ALL BOLTS TO BE 3/4" DIAMETER UNLESS NOTED OTHERWISE. SHOP CONNECTIONS MAY BE WELDED OR BOLTED. WELDS ARE TO BE EQUAL IN STRENGTH TO BOLTS. ALL FIELD CONNECTIONS ARE TO BE BOLTED WITH ASTM A325N OR A490 BOLTS (BEARING TYPE BOLTS WITH THREADS IN THE SHEAR PLANE) INCLUDING SUITABLE NUTS AND PLAIN HARDENED WASHERS. ALL BOLTS SHALL BE TIGHTENED SNUG TIGHT UNLESS OTHERWISE NOTED. DESIGN CONNECTIONS FOR THE LARGER OF EITHER THE SHEAR SHOWN ON THE DRAWINGS, (INDICATED AS "V =K" AT ENDS OF MEMBER) OR 55% OF THE MAXIMUM LOAD(IN KIPS) LISTED IN THE TABLES FOR "MINIMUM TOTAL FACTORED UNIFORM LOADS IN KIPS FOR BRACED, SIMPLE SPAN BEAMS BENT ABOUT THE STRONG AXIS" OF THE LATEST EDITION OF THE AISC "MANUAL OF STEEL CONSTRUCTION".
- SIZE AND USE OF HOLES: SEE AISC TABLE J3.3.
 - LARGER HOLES ARE PERMITTED IN STANDARD COLUMN BASE PLATES. MAXIMUM HOLE DIAMETER = BOLT DIAMETER + 3/8". HARDENED WASHERS, TO COVER THE LARGER HOLE, SHALL BE PROVIDED.
 - LARGER HOLES ARE NOT PERMITTED IN WIND FRAME COLUMN BASE PLATES. MAXIMUM HOLE DIAMETER = BOLT DIAMETER + 1/16".
 - SLOTTED HOLES: A PLATE WASHERS OR A CONTINUOUS BAR WITH STANDARD HOLES, HAVING A SIZE SUFFICIENT TO COMPLETELY COVER THE SLOT AFTER INSTALLATION, AND A MIN. OF 5/16" THICK SHALL BE PROVIDED. TACK WELD NUT TO BOLT AFTER ERECTION.
- STEEL BEAMS SHALL BE FABRICATED WITH THE NATURAL CAMBER (WITHIN THE MILL TOLERANCE) LOCATED ABOVE THE HORIZONTAL CENTERLINE BETWEEN THE END CONNECTIONS.
- SHOP PRIME STEEL SURFACES EXCEPT THE FOLLOWING:
 - SURFACES EMBEDDED IN CONCRETE OR MORTAR. EXTEND PRIMING OF PARTIALLY EMBEDDED MEMBERS TO A DEPTH OF 2 INCHES.
 - SURFACES TO BE FIELD WELDED.
 - SURFACES TO BE HIGH-STRENGTH BOLTED WITH SLIP-CRITICAL CONNECTIONS.
 - SURFACES TO RECEIVE SPRAYED FIRE-RESISTIVE MATERIALS.
 - GALVANIZED SURFACES.
 - FINISH BY ARCHITECT.
- SURFACE PREPARATION: CLEAN SURFACES TO BE PAINTED. REMOVE LOOSE RUST AND MILL SCALE AND SPATTER, SLAG, OR FLUX DEPOSITS. PREPARE SURFACES ACCORDING TO THE FOLLOWING SPECIFICATIONS AND STANDARDS.
 - STRIPE PAINT CORNERS, CREVICES, BOLTS, WELDS, AND SHARP EDGES.
- APPLY TWO COATS OF SHOP PAINT TO INACCESSIBLE SURFACES AFTER ASSEMBLY OR ERECTION. CHANGE COLOR OF SECOND COAT TO DISTINGUISH IT FROM FIRST.
- PRIME AND PAINT ALL FIELD WELDS AFTER INSPECTION.
- A QUALIFIED TESTING LABORATORY SHALL BE RETAINED TO PERFORM THE FOLLOWING TESTS.
 - VISUALLY INSPECT ALL STEEL MEMBERS AND CONNECTIONS.
 - TEST 50 PERCENT OF FULL PENETRATION WELDS.
- ONE COPY OF ALL TEST REPORTS SHALL BE SENT DIRECTLY TO OWNER, ARCHITECT, STRUCTURAL ENGINEER, AND GENERAL CONTRACTOR.
- STEEL SHALL CONFORM TO:

WIDE FLANGE (WF)(WT)-----ASTM A992 (50 KSI)
SHAPES (S, L, C, MC)-----ASTM A36
HOLLOW STRUCTURAL SECTIONS (HSS)---ASTM A500 GRADE C (RECTANGULAR 50 KSI; ROUND 46 KSI)
ANCHOR BOLTS-----ASTM A307
FRAMING BOLTS-----ASTM A325N OR A490N
WELDING ELECTRODES-----E70XX

- FASTENERS AND MATERIALS USED FOR WELDING OR OTHERWISE SECURING COMPONENTS ONE TO ANOTHER SHALL BE OF DOMESTIC (USA MADE) MANUFACTURE. SIMILARLY, ALL MATERIALS USED IN THE MANUFACTURING PROCESS SHALL BE FROM A DOMESTIC SOURCE.
- SHOP AND FIELD WELDS SHALL BE DONE BY A.W.S. CERTIFIED WELDERS. PROVIDE CURRENT CERTIFICATES UPON REQUEST.
- NO SPLICES SHALL BE PERMITTED IN ANY STRUCTURAL STEEL MEMBER UNLESS SHOWN ON APPROVED SHOP DRAWINGS.
- STEEL STAIRS AND/OR LADDERS SHALL BE DESIGNED FOR 100 PSF LIVE LOAD BY A LICENSED DELEGATED ENGINEER, WHO SHALL SUBMIT SIGNED AND SEALED SHOP DRAWINGS. SHOP DRAWINGS SHALL SPECIFY ALL DESIGN LOADS.
- SUBMITTALS: CONTRACTOR SHALL SUBMIT DETAILED SHOP DRAWINGS SHOWING ALL STRUCTURAL STEEL LAYOUTS AND DETAILS, SIZES OF MEMBERS, TYPE OF STEEL, CONNECTION DETAILS, WELDS, BOLTS, ETC., AS REQUIRED TO FABRICATE AND ERECT ALL STRUCTURAL STEEL FRAMING. ALL CONNECTIONS NOT SHOWN ON THE STRUCTURAL DRAWINGS SHALL BE DESIGNED BY THE DETAILER AND SUBMITTED ON SHOP DRAWINGS, SIGNED AND SEALED BY A REGISTERED FLORIDA DELEGATED ENGINEER.
- NON-SHRINK GROUT SHALL BE: NONMETALLIC SHRINKAGE-RESISTANT GROUT, PREMIXED, NON-CORROSIVE, NON-STAINING PRODUCT CONTAINING SELECTED SILICA SANDS, PORTLAND CEMENT, SHRINKAGE COMPENSATING AGENTS, PLASTICIZING AND WATER-REDUCING AGENTS, COMPLYING WITH CRD-C621, CORPS OF ENGINEERS.
- IF NOT SPECIFIED ON THE DRAWINGS, THE THROAT SIZE OF ANY FILLET WELD SHALL BE EQUAL TO 1/16" LESS THAN THE THINNEST CONNECTION COMPONENT.
- NO FIELD WELDING OF GALVANIZED MEMBERS IS PERMITTED.
- MINIMUM EMBEDMENT DEPTH OF ANCHOR BOLTS:
 - FOOTINGS = 3" FROM BOTTOM.
- ERECTION
 - BEFORE ERECTION, THE CONTRACTOR IS TO REMOVE ALL MUD, DIRT OR OTHER FOREIGN MATTER, WHICH ACCUMULATES DURING HANDLING AND STORAGE.
 - DRIFTING TO ENLARGE UNFAIR HOLES WILL NOT BE PERMITTED. DRILL SUCH HOLES TO ACCOMMODATE THE NEXT LARGER SIZE FASTENER, WHERE POSSIBLE.
 - AFTER ERECTION, CLEAN FIELD WELDS, BOLTED CONNECTIONS, AND ABRADED AREAS WHERE SHOP COAT HAS BEEN DAMAGED. SPOT AND PRIME AREAS USING SAME MATERIAL AS SHOP COAT.
 - SET ALL MEMBERS SO THAT, IN THEIR FINAL LOCATION, LEVEL, PLUMBNESS AND ALIGNMENT ARE WITHIN THE TOLERANCES PRESCRIBED BY AISC CODE.
 - DOUBLE CONNECTIONS THROUGH COLUMN WEBS OR AT BEAMS THAT FRAME OVER THE TOPS OF COLUMNS MUST BE DESIGNED TO HAVE AT LEAST ONE INSTALLED BOLT REMAIN IN PLACE TO SUPPORT THE FIRST BEAM WHILE THE SECOND BEAM IS BEING ERECTED. ALTERNATIVELY, THE FABRICATOR MUST SUPPLY A SEAT OR EQUIVALENT DEVICE WITH A MEANS OF POSITIVE ATTACHMENT TO SUPPORT THE FIRST BEAM WHILE THE SECOND BEAM IS BEING ERECTED.

CARPENTRY

- DIMENSIONED LUMBER SHALL BE DRESSED S4S, AND SHALL BEAR THE GRADE STAMP OF THE MANUFACTURER'S ASSOCIATION.
- LUMBER SHALL BE SOUND, SEASONED, AND FREE FROM WARP.
- LUMBER SHALL BE SOUTHERN PINE NO. 2 GRADE OR BETTER; WITH 19% MAXIMUM MOISTURE CONTENT, UNLESS NOTED OTHERWISE ON THE PLANS.
- LUMBER IN CONTACT WITH MASONRY OR CONCRETE, OR EXPOSED TO WEATHER, SHALL BE PRESSURE TREATED.
- MINIMUM COATING REQUIREMENTS FOR METAL CONNECTORS AND FASTENERS:
 - EXTERIOR COASTAL AREAS - STAINLESS STEEL (TYPE 316L)
- WHEN USING STAINLESS STEEL CONNECTORS, USE STAINLESS STEEL FASTENERS. WHEN USING G185 OR HDG CONNECTORS, USE FASTENERS GALVANIZED PER ASTM A153.
- PLYWOOD SHEATHING SHALL BE DFPA CD WITH EXTERIOR GLUE. ALL ROOF SHEATHING TO BE INSTALLED WITH PLYCLIPS.
- INSTALL BRIDGING IN ALL FLOOR OR ROOF JOISTS AT 10'-0" O.C. MAXIMUM.
- NAILING AND BOLTING SHALL COMPLY WITH AMERICAN INSTITUTE OF TIMBER CONSTRUCTION REQUIREMENTS.
- CONNECTION HARDWARE SHALL BE SUPPLIED BY SIMPSON STRONG-TIE CO., INC. OR EQUIVALENT. SUBMIT CUT SHEETS OF ALTERNATIVE CONNECTION HARDWARE TO ENGINEER FOR APPROVAL.
- ROOF SHEATHING SHALL BE 5/8" EXTERIOR GRADE PLYWOOD OR OSB NAILED WITH 10D NAILS AT 4" O.C. AT SUPPORTED EDGES, AND 10D NAILS AT 6" O.C. AT INTERMEDIATE SUPPORTS. PROVIDE ONE PLYWOOD CLIP PER SPAN BETWEEN SHEET EDGES. PROVIDE SOLID 2X BLOCKING BETWEEN SUPPORTS AT ALL HIPS, RIDGES, VALLEYS, AND CHANGES IN ROOF SLOPE. USE RING SHANK NAILS WHERE MEAN ROOF HEIGHT EXCEEDS 25'-0".
- FASTENER SUBSTITUTIONS

ALL NAILS ARE COMMON NAILS, UNLESS NOTED OTHERWISE. THE FOLLOWING FASTENERS ARE ACCEPTABLE SUBSTITUTIONS. ALL ALTERNATE FASTENERS SHALL BE SPACED AT THE SAME SPACING AS THE SCHEDULED FASTENERS.

SCHEDULED FASTENER	ALTERNATE FASTENER
8D COMMON NAIL	8D RING SHANK NAIL 8D SCREW SHANK NAIL 0.131 P-NAIL
10D COMMON NAIL	10D RING SHANK NAIL 10D SCREW SHANK NAIL 0.148 P-NAIL
6D COOLER NAIL	#6 X 1-1/4" TYPE S OR W DRYWALL SCREW

THIS DRAWING IS NOT FOR CONSTRUCTION. IT HAS BEEN ISSUED FOR GOVERNMENTAL REVIEW AND/OR PRELIMINARY PRICING ONLY.

- GUN DRIVEN NAILS MUST BE SUBMITTED FOR REVIEW WITH APPROPRIATE BACK-UP DATA.
- OSB SHALL NOT HAVE A MOISTURE CONTENT GREATER THAN 15%. PROLONGED EXPOSURE TO WETTING & MOISTURE WILL DAMAGE AND REDUCE THE STRUCTURAL CAPACITY OF THE SHEATHING. SPECIAL CARE SHALL BE TAKEN DURING CONSTRUCTION TO KEEP THE OSB DRY AT ALL TIMES (INCLUDING DURING TRANSPORTATION, STORAGE, INSTALLATION, ETC.)
- PRESSURE TREATED WOOD TABLE: AWWA STANDARD U1-11

APPLICATION	EXPOSURE	USE CATEGORY	COMMODITY SPECIFICATION AND SECTION	PRESERVATIVE RETENTION
DECKING, JOISTS AND BEAMS	ABOVE GROUND, EXTERIOR	3B	A	NOTE 1

NOTES: 1. REFER TO AWWA U1-11 FOR ALLOWABLE PRESERVATIVES AND RETENTIONS.

REX® WOOD POLYMER COMPOSITE LUMBER DECKING OR EQUAL

- MANUFACTURER = TREX COMPANY, INC., WWW.TREX.COM, PHONE NUMBER 540-542-6300.
- TREX® IS A MANUFACTURED COMPOSITE MATERIAL THAT CONSISTS OF APPROXIMATELY 50 PERCENT WOOD FIBERS OR OTHER CELLULOSIC FIBERS BY WEIGHT WITH THE REMAINDER OF THE MATERIAL BEING THERMOPLASTIC POLYMER PLASTIC MATERIAL.
- TREX® SHALL BE IDENTIFIED BY A STAMP OR NON-REMOVABLE LABEL, SPACED AT REGULAR

INTERVALS ALONG EACH PIECE NOTING THE FOLLOWING INFORMATION:
A) ICC-ES LEGACY REPORT NUMBER ICC-ES NER-508.
B) MANUFACTURER'S NAME OR TRADEMARK, AND PRODUCT DESCRIPTION.
C) NAME OF THE QUALITY CONTROL AGENCY, PFS CORPORATION (NER-QA251), OR THEIR TRADEMARK.
D) DATE OF MANUFACTURE.

- TREX® SHALL NOT BE USED AS A COMPONENT OF TRUSSES OR STRUCTURAL DIAPHRAGMS AND SHALL NOT BE USED IN INTERIOR FRAMING APPLICATIONS.
- THE DESIGN AND INSTALLATION OF TREX® SHALL BE IN ACCORDANCE WITH THE MANUFACTURER'S PUBLISHED INSTALLATION INSTRUCTIONS.
- TREX® USED AS DECKING SHALL BE DESIGNED AND INSTALLED TO LIMIT BENDING DEFLECTION UNDER TOTAL DESIGN LOAD TO LESS THAN OR EQUAL TO L/360.
- TREX® DECKING SHALL BE GAPPED TO PERMIT ADEQUATE DRAINAGE IN ACCORDANCE WITH THE MANUFACTURER'S INSTRUCTIONS.
- THE MAXIMUM HEIGHT OF THE GUARDRAIL ASSEMBLY SHALL BE 42 INCHES FROM THE DECK BOARDS. THE MAXIMUM OPENING UNDER THE BOTTOM RAIL SHALL BE THREE (3) INCHES.
- IN LIEU OF TREX DECKING, APPROVED EQUAL MUST HAVE FOLLOWING DESIGN PROPERTIES:
 - FC= 540 PSI
 - FC1=540 PSI
 - FB= 500 PSI
 - FV=360 PSI
E=200,000 PSI

STRUCTURAL DRAWING INDEX
S0.1 STRUCTURAL SPECIFICATIONS
S0.2 STRUCTURAL SPECIFICATIONS & WIND LOAD SCHEDULE
S1.0 PARTIAL STAIR FOUNDATION PLAN
S1.1 PARTIAL RAMP FOUNDATION PLANS AND DETAILS
S1.2 STAIR ROOF FRAMING PLAN, SECTIONS AND DETAILS
S2.0 DETAILS
S2.1 SECTIONS AND DETAILS

WILLIAM P. HORN
ARCHITECT , P.A.

915 EATON ST.
KEY WEST,
FLORIDA
33040

TEL (305) 296-8302
FAX (305) 296-1033

LICENSE NO.
AA 0003040

**BIG PINE ACADEMY
ADA ACCESS
COMPLIANCE
RENOVATION**

30220 OVERSEAS HWY.
BIG PINE KEY, FLORIDA

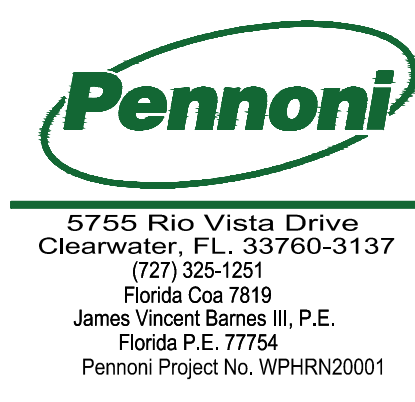

SEAL

DATE
01-28-2022 - BID SET

REVISIONS

DRAWN BY
SV

PROJECT NUMBER
2105

NOT FOR CONSTRUCTION - NOT FOR FINAL PRICING - SUBJECT TO CHANGE

BIG PINE ACADEMY ADA ACCESS COMPLIANCE RENOVATION
30220 OVERSEAS HIGHWAY
BIG PINE KEY, FLORIDA 33043

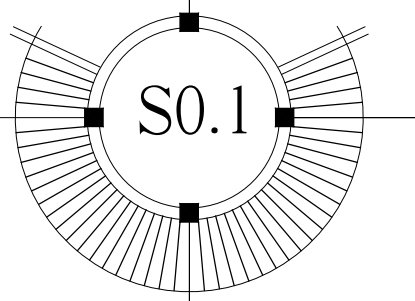

STRUCTURAL SPECIFICATIONS CONT.

CAST IN PLACE CONCRETE

- ALL CAST-IN-PLACE CONCRETE WORK INCLUDES REINFORCING STEEL AND RELATED WORK SHOWN INCLUDING FORMWORK, SETTING ANCHOR BOLTS, PLATES, FRAMES, DOWELS FOR MASONRY OR OTHER ITEMS EMBEDDED IN CONCRETE.
- APPLICABLE STANDARDS

ACI NUMBER	TITLE
117	STANDARD SPECIFICATIONS FOR TOLERANCES FOR CONCRETE CONSTRUCTION
226	GROUND GRANULATED BLAST-FURNACE SLAG
301	STANDARD SPECIFICATIONS FOR STRUCTURAL CONCRETE FOR BUILDINGS
302	GUIDE FOR CONCRETE FLOOR AND SLAB CONSTRUCTION
304	GUIDE FOR MEASURING MIXING, TRANSPORTING AND PLACING CONCRETE
304.2R	PLACING CONCRETE BY PUMPING METHODS.
305R	HOT WEATHER CONCRETING
306R	COLD WEATHER CONCRETING
308	STANDARD PRACTICE FOR CURING CONCRETE
309R	GUIDE FOR CONSOLIDATION OF CONCRETE
315	MANUAL OF STANDARD PRACTICE FOR DETAILING CONCRETE STRUCTURES
318	BUILDING CODE REQUIREMENTS FOR REINFORCED CONCRETE
347	RECOMMENDED PRACTICE FOR CONCRETE FORMWORK
CRSI NUMBER/TITLE	
63	RECOMMENDED PRACTICE FOR PLACING REINFORCING BARS
- CONCRETE MATERIALS
 - PORTLAND CEMENT – ASTM C 150, TYPE I
 - AGGREGATES – NORMAL WEIGHT CONCRETE, COARSE AND FINE, ASTM C 33. STRUCTURAL LIGHT WEIGHT ASTM C 330.
 - AIR-ENTRAINING – ASTM C 260
 - WATER REDUCING – ASTM C 494, TYPE A
 - WATER – FRESH, CLEAN AND POTABLE
 - NO ACCELERATORS, RETARDERS OR ADMIXTURES CONTAINING CHLORIDES WILL BE PERMITTED
 - FLY-ASH – ASTM C 618, CLASS F, 20% MAXIMUM OF CEMENTITIOUS MATERIAL BY WEIGHT. DO NOT USE FOR EXPOSED SLABS OR ARCHITECTURAL CONCRETE.
 - SUPER PLASTICIZER – ASTM C 494, TYPE F OR G, WHERE AUTHORIZED BY THE ENGINEER.
 - GROUND GRANULATED BLAST-FURNACE SLAG CEMENT – ASTM C 989, 50% MAXIMUM BY WEIGHT.
 - MAXIMUM AGGREGATE SIZE – FOOTINGS = #57, OTHERS #67
- REINFORCING MATERIALS
 - DEFORMED BARS – ASTM A 615, GRADE 60
 - WELDED WIRE FABRIC – ASTM A 1064, PLAIN WIRE FABRIC IN FLAT SHEETS ONLY.
 - ACCESSORIES TO CONFORM TO ACI 315.
 - WHERE CONCRETE SURFACES ARE EXPOSED, MAKE THOSE PORTIONS OF ALL ACCESSORIES IN CONTACT WITH THE CONCRETE SURFACE OR WITHIN 1/2 INCH THEREOF, OF PLASTIC OR STAINLESS STEEL.
- PROVIDE THE FOLLOWING MINIMUM CONCRETE STRENGTHS AT 28 DAYS:
 - FOOTINGS, SLAB-ON-GRADE, GRADE BEAM, PIER EXTENSION -----3000 PSI
- CONCRETE MUST BE BATCHED, MIXED AND TRANSPORTED IN ACCORDANCE WITH THE SPECIFICATIONS FOR READY-MIXED CONCRETE ASTM C 94.
- REQUIRED SLUMP = 4 PLUS OR MINUS ONE INCH.
- CONCRETE MUST BE PLACED WITHIN 90 MINUTES OF BATCH TIME. WHEN AIR TEMPERATURE IS BETWEEN 85 AND 90 DEGREES F, REDUCE MIXING AND DELIVERY TIME TO 75 MINUTES. WHEN AIR TEMPERATURE IS HIGHER THAN 90 DEGREES F, REDUCE MIXING AND DELIVERY TIME TO 60 MINUTES.
- DO NOT ADD WATER AT THE JOB SITE WITHOUT APPROVAL OF THE PROJECT SUPERINTENDENT. DO NOT EXCEED THE SLUMP LIMITATION. USE ONLY COLD WATER FROM THE TRUCK TANK. ANY ADDED WATER MUST BE INDICATED ON THE DELIVERY TICKET PLUS THE NAME OF THE PERSON AUTHORIZING. TEST CYLINDERS SHALL BE TAKEN AFTER THE ADDITION OF WATER.
- LAP SPLICE REINFORCING PER CONCRETE LAP SCHEDULE MINIMUM UNLESS OTHERWISE SHOWN OR NOTED.
- PROVIDE FOUNDATION DOWELS TO MATCH SIZE AND NUMBER OF VERTICAL BARS. EMBED DOWELS TO:
 - 3" ABOVE BOTTOM OF FOOTINGS, GRADE BEAMS, PIER EXTENSIONS.
- REINFORCEMENT SHALL BE FASTENED AND SECURED TOGETHER TO PREVENT DISPLACEMENT BY CONSTRUCTION LOADS OR THE PLACING OF CONCRETE.
- REINFORCING BAR COVER
 - FOOTINGS, GRADE BEAM, PIER EXTENSIONS 2" (TOP), 3" (SIDES AND BOTTOM)
 - SLABS 1-1/2" (EXTERIOR)
- WHERE BAR LENGTHS ARE GIVEN ON THE DRAWINGS, LENGTH OF HOOK, IF REQUIRED, IS NOT INCLUDED.
- SELECT PROPORTIONS IN ACCORDANCE WITH ACI 301 TO PROVIDE CONCRETE CAPABLE OF BEING PLACED WITHOUT EXCESSIVE SEGREGATION AND WITH ACCEPTABLE FINISHING PROPERTIES, DURABILITY, SURFACE HARDENERS, APPEARANCE, AND STRENGTH REQUIREMENTS REQUIRED BY THESE SPECIFICATIONS.
- CHAIR WELDED WIRE FABRIC REINFORCING AT 3'-0" ON CENTER MAXIMUM IN EACH DIRECTION.

- MAXIMUM WATER TO CEMENT RATIO WHEN NO BACK-UP DATA IS AVAILABLE:
 - 3000 PSI, 28-DAY COMPRESSIVE STRENGTH; W/C RATIO, 0.58 MAXIMUM (NON-AIR-ENTRAINED), 0.47 MAXIMUM (AIR-ENTRAINED).
- DATA TO BE SUBMITTED:
 - INTENDED USAGE AND LOCATION FOR EACH TYPE
 - MIX DESIGN FOR EACH TYPE
 - CEMENT CONTENT IN POUNDS-PER-CUBIC YARD
 - COARSE AND FINE AGGREGATE IN POUNDS/CUBIC YARD
 - WATER CEMENT RATIO BY WEIGHT
 - CEMENT TYPE AND MANUFACTURER
 - SLUMP RANGE
 - AIR CONTENT
 - ADMIXTURE TYPE AND MANUFACTURER
 - PERCENT ADMIXTURE BY WEIGHT
 - STRENGTH TEST DATA REQUIRED TO ESTABLISH MIX DESIGN.
 - COMPLETE DETAIL AND PLACING SHOP DRAWINGS FOR ALL REINFORCING STEEL INCLUDING ACCESSORIES THAT HAVE BEEN REVIEWED AND STAMPED BY THE GENERAL CONTRACTOR. INCLUDE ALL REQUIRED DIMENSIONS AND ELEVATIONS (I.E. TOP OF CONCRETE)
- THE GENERAL CONTRACTOR IS RESPONSIBLE FOR PROVIDING THE CONSTRUCTION OF FORMWORK, SHORING AND RE-SHORING IN ACCORDANCE WITH ACI 347.
 - FORM AND SHORING DESIGN BY A P.E. REGISTERED IN THE STATE OF FLORIDA.
- SUBMIT FORM WORK AND SHORING DRAWINGS TO LOCAL BUILDING DEPARTMENT WHEN REQUIRED BY FLORIDA THRESHOLD LAW.
- CONSTRUCTION JOINTS NOT SHOWN ON THE DRAWINGS MUST BE MADE AND LOCATED TO LEAST IMPAIR THE STRENGTH OF THE STRUCTURE.
 - NO HORIZONTAL CONSTRUCTION JOINTS WILL BE PERMITTED IN BEAMS, GIRDERS AND SLABS.
 - LOCATION OF ANY CONSTRUCTION JOINT NOT SHOWN IS SUBJECT TO REVIEW AND ACCEPTANCE BY ENGINEER.
- INTERNAL VIBRATION, PROPERLY APPLIED IS THE REQUIRED METHOD OF CONSOLIDATING PLASTIC CONCRETE.
- CONTRACTOR SHALL VERIFY LOCATIONS OF ALL OPENINGS, SLEEVES, AND SLAB RECESSES AS REQUIRED BY OTHER TRADES BEFORE CONCRETE IS PLACED. NO SLEEVE, OPENINGS, OR INSERT MAY BE PLACED IN BEAMS, JOISTS, OR COLUMN UNLESS APPROVED BY THE ENGINEER.
- CONTRACTOR SHALL VERIFY EMBEDDED ITEMS INCLUDING, BUT NOT LIMITED TO, ANCHOR BOLTS, BOLT CLUSTERS, WELD PLATES, ETC., BEFORE PLACING CONCRETE. NOTIFY ENGINEER OF ANY CONFLICTS WITH REBAR.
- ALL EXPOSED CONCRETE SURFACES TO BE IN ACCORDANCE WITH ACI 301 SECTION 5.3.3.(C), INCLUDING SURFACE TOLERANCE CLASS A AS SPECIFIED IN ACI 117.U.N.O.
- SEE ARCHITECTURAL DRAWINGS FOR REQUIRED CONCRETE FINISHES.
- SLOPE WALKWAYS TO DRAIN AWAY FROM THE BUILDING.
- TESTING
 - A QUALIFIED TESTING LAB SHALL BE RETAINED TO PERFORM QUALITY CONTROL WORK AND ON-SITE TESTING.
 - SLUMP TEST – ASTM 143
 - MOLD AND CURE TEST CYLINDERS (ASTM C-31) AND TEST CYLINDERS FOR STRENGTH (ASTM C39). TAKE ONE TEST – THREE CYLINDERS FOR EACH DAYS POUR OF 100 CUBIC YARDS, OR FRACTION THEREOF. TEST ONE CYLINDER AT 7 DAYS, TWO AT 28 DAYS. TEST CYLINDER SAMPLES SHALL BE TAKEN AT THE POINT OF DISCHARGE WHEN USING A PUMP.
 - ONE COPY OF ALL TEST REPORTS SHALL BE SENT DIRECTLY TO THE OWNER, ENGINEER, ARCHITECT AND GENERAL CONTRACTOR.
- CONTRACTOR SHALL PROVIDE FLATNESS AND LEVELNESS IN CONCRETE SLABS PER ACI 302.1R, FIG. 10.7 MINIMUM REQUIRED "F" NUMBERS FOR TYPE OF SLAB USE. REFER TO ACI 117 FOR FLOOR TOLERANCES.
- REPAIR ANY CRACKS OR DEFECTIVE AREAS THAT WILL RESTORE THE AFFECTED SURFACE OR AREAS TO THEIR FULL DESIGN STRENGTH AND APPEARANCE. CONTACT THE STRUCTURAL ENGINEER FOR ADVICE AND EVALUATION.
- ACCEPTANCE OF THE STRUCTURE WILL BE MADE IN CONFORMANCE WITH ACI 301.
- ALL CAST-IN-PLACE CONCRETE MUST BE MAINTAINED WITH MINIMAL MOISTURE LOSS AT A RELATIVELY CONSTANT TEMPERATURE FOR A MINIMUM OF 7 DAYS FOLLOWING THE PLACING OF THE CONCRETE BY THE USE OF A WATER SPRAY, WATER SATURATED FABRIC, MOISTURE RETAINING MEMBRANE OR LIQUID CURING COMPOUND.
- CURE SLABS-ON-GRADE FOR THE FIRST 72 HOURS BY THE USE OF:
 - FOG SPRAYING
 - PONDING
 - SPRINKLING
 - CONTINUOUSLY WET ABSORPTIVE MATS OR FABRIC
 - CONTINUE CURING BY USE OF MOISTURE RETAINING COVER UNTIL CONCRETE HAS OBTAINED ITS SPECIFIED 28 DAY COMPRESSIVE STRENGTH.
 - OR LIQUID CURING COMPOUND AFTER FINISHING PROCESS IS COMPLETED.
 - CONCRETE WET CURE TIME TO BE 7 DAYS MINIMUM AT 50 DEGREES MINIMUM TEMPERATURE.
- SUBMIT MATERIALS AND METHOD OF CURING FOR REVIEW.
- DO NOT USE MOISTURE RETAINING CURING COMPOUNDS FOR CURING SURFACES TO RECEIVE CARPET, FLEXIBLE FLOORING, CERAMIC TILED FLOORS OR OTHER SPECIFIED FLOOR SYSTEMS, UNLESS IT HAS BEEN DEMONSTRATED THAT SUCH COMPOUNDS WILL NOT PREVENT BOND.
- DO NOT PERMIT CONCRETE NOT FULLY CURED TO BE EXPOSED TO EXCESSIVE TEMPERATURE CHANGES OR HIGH WINDS.

- POUR ALL GROUND SLABS ON 10 MIL MINIMUM VAPOR RETARDER IN COMPLIANCE WITH ASTM E1745, LAPPED 6" MINIMUM AND FULLY TAPED.
- EQUIPMENT MADE OF ALUMINUM OR ALUMINUM ALLOYS, SHALL NOT BE USED FOR PUMP LINES, TREMIES, OR CHUTES OTHER THAN SHORT CHUTES SUCH AS THOSE USED TO CONVEY CONCRETE FROM A TRUCK MIXER.
- THE CODE PROHIBITS THE USE OF ALUMINUM (CONDUIT, PIPES, ETC.) IN STRUCTURAL CONCRETE UNLESS IT IS EFFECTIVELY COATED OR COVERED.

THIS DRAWING IS NOT FOR CONSTRUCTION. IT HAS BEEN ISSUED FOR GOVERNMENTAL REVIEW AND/OR PRELIMINARY PRICING ONLY.

GROSS ULTIMATE WIND LOADS MAIN ROOF ROOFING MATERIALS			
COMPONENTS AND CLADDING	ROOF ZONE		
	1	2	3
PRESSURE (psf)	80.9	121.0	162.0
SUCTION (psf)	-80.9	-121.0	-197.0

NET ULTIMATE WIND LOADS MAIN ROOF TRUSSES			
COMPONENTS AND CLADDING	ROOF ZONE		
	1	2	3
PRESSURE (psf)	80.9	121.0	121.0
SUCTION (psf)	-80.9	-121.0	-121.0

GROSS ULTIMATE WIND LOADS MAIN ROOF ROOFING MATERIALS			
COMPONENTS AND CLADDING	ROOF ZONE		
	1	2	3
PRESSURE (psf)	79.3	122.0	159.0
SUCTION (psf)	-104.0	-162.0	-209.0

NET ULTIMATE WIND LOADS MAIN ROOF JOISTS OR TRUSSES			
COMPONENTS AND CLADDING	ROOF ZONE		
	1	2	3
PRESSURE (psf)	79.3	79.3	79.3
SUCTION (psf)	-104.0	-104.0	-104.0

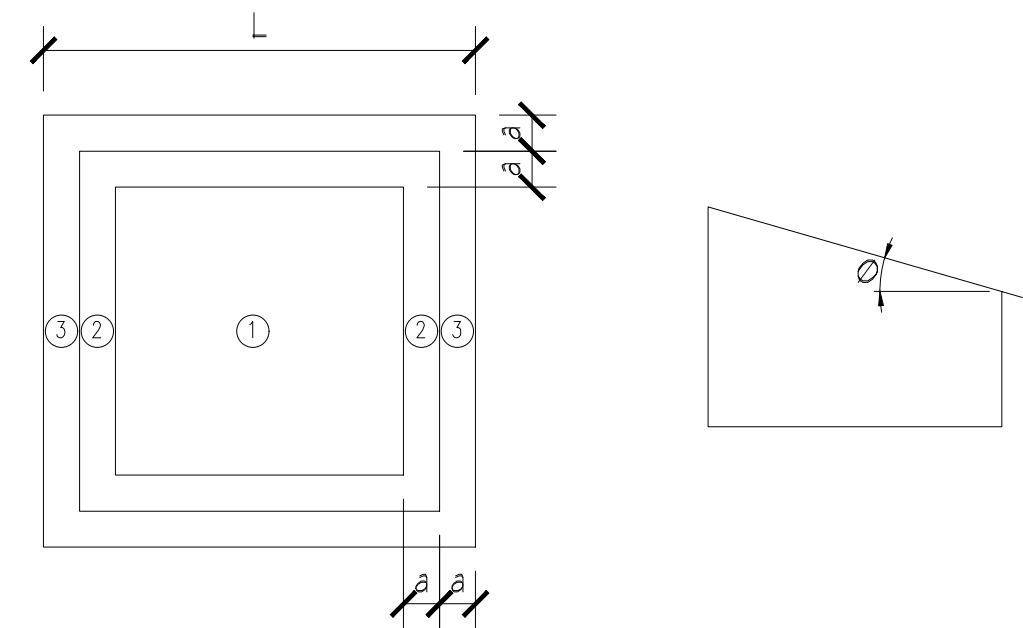

MONOSLOPE FREE ROOF (PRE-ENGINEERED CANOPY) ($0^\circ < \theta < 45^\circ$)

COMPONENT AND CLADDING LOADING DIAGRAMS

- $a=3'-0"$
- THIS BUILDING IS DESIGNED AS AN ENCLOSED STRUCTURE. ALL EXTERIOR COMPONENTS (DOORS, WINDOWS, ETC.) MUST BE DESIGNED TO WITHSTAND THE WIND LOADINGS SPECIFIED FOR THE DESIGN OF COMPONENTS AND CLADDING IN THE TABLES. IN ADDITION, ALL AREAS OF EXTERIOR GLAZING MUST BE CERTIFIED FOR MISSILE IMPACT OR PROTECTED BY WIND-BORNE DEBRIS BY A SCREEN BARRIER.
- TO CONVERT THE (ASCE 7-16) ULTIMATE WIND PRESSURES IN THE TABLES ABOVE TO (ASD) WIND PRESSURES, MULTIPLY EACH VALUE BY ϕ_w .

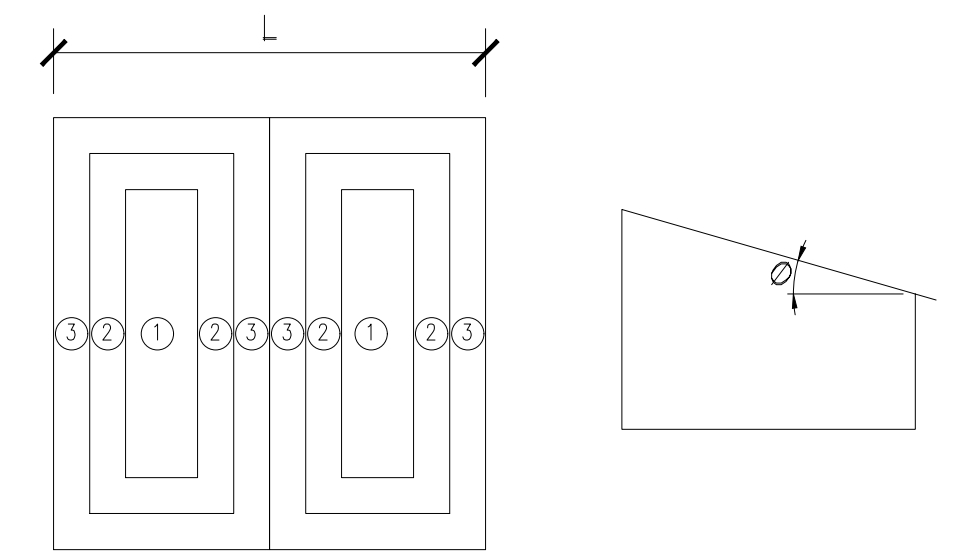

PITCHED FREE ROOF (ROOF ADDITION) ($10^\circ < \theta < 45^\circ$)

COMPONENT AND CLADDING LOADING DIAGRAMS

- $a=3'-0"$
- THIS BUILDING IS DESIGNED AS AN ENCLOSED STRUCTURE. ALL EXTERIOR COMPONENTS (DOORS, WINDOWS, ETC.) MUST BE DESIGNED TO WITHSTAND THE WIND LOADINGS SPECIFIED FOR THE DESIGN OF COMPONENTS AND CLADDING IN THE TABLES. IN ADDITION, ALL AREAS OF EXTERIOR GLAZING MUST BE CERTIFIED FOR MISSILE IMPACT OR PROTECTED BY WIND-BORNE DEBRIS BY A SCREEN BARRIER.
- TO CONVERT THE (ASCE 7-16) ULTIMATE WIND PRESSURES IN THE TABLES ABOVE TO (ASD) WIND PRESSURES, MULTIPLY EACH VALUE BY ϕ_w .

WILLIAM P. HORN
ARCHITECT, P.A.

915 EATON ST.
KEY WEST,
FLORIDA
33040

TEL (305) 296-8302
FAX (305) 296-1033

LICENSE NO.
AA 0003040

BIG PINE ACADEMY
ADA ACCESS
COMPLIANCE
RENOVATION

30220 OVERSEAS HWY.
BIG PINE KEY, FLORIDA



SEAL

DATE
01-28-2022 - BID SET

REVISIONS

DRAWN BY
SV

PROJECT NUMBER
2105

NOT FOR CONSTRUCTION – NOT FOR FINAL PRICING – SUBJECT TO CHANGE

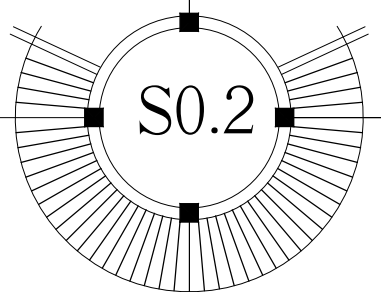

FOOTING SCHEDULE					
MARK	SIZE	DEPTH	REINF. EA. WAY	REMARKS	DWL/A.B. EMBEDMENT
F30	3'-0"X3'-0"	1'-0"	(3) #5		9"

THIS DRAWING IS NOT FOR CONSTRUCTION. IT HAS BEEN ISSUED FOR GOVERNMENTAL REVIEW AND/OR PRELIMINARY PRICING ONLY.

WILLIAM P. HORN
ARCHITECT, P.A.

915 EATON ST.
KEY WEST,
FLORIDA
33040

TEL (305) 296-8302
FAX (305) 296-1033

LICENSE NO.
AA 0003040

BIG PINE ACADEMY
ADA ACCESS
COMPLIANCE
RENOVATION
30220 OVERSEAS HWY.
BIG PINE KEY, FLORIDA



SEAL

NOT FOR CONSTRUCTION - NOT FOR FINAL PRICING - SUBJECT TO CHANGE

DATE
01-28-2022 - BID SET

REVISIONS

DRAWN BY
SV

PROJECT NUMBER
2105

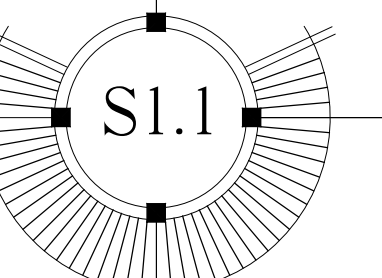
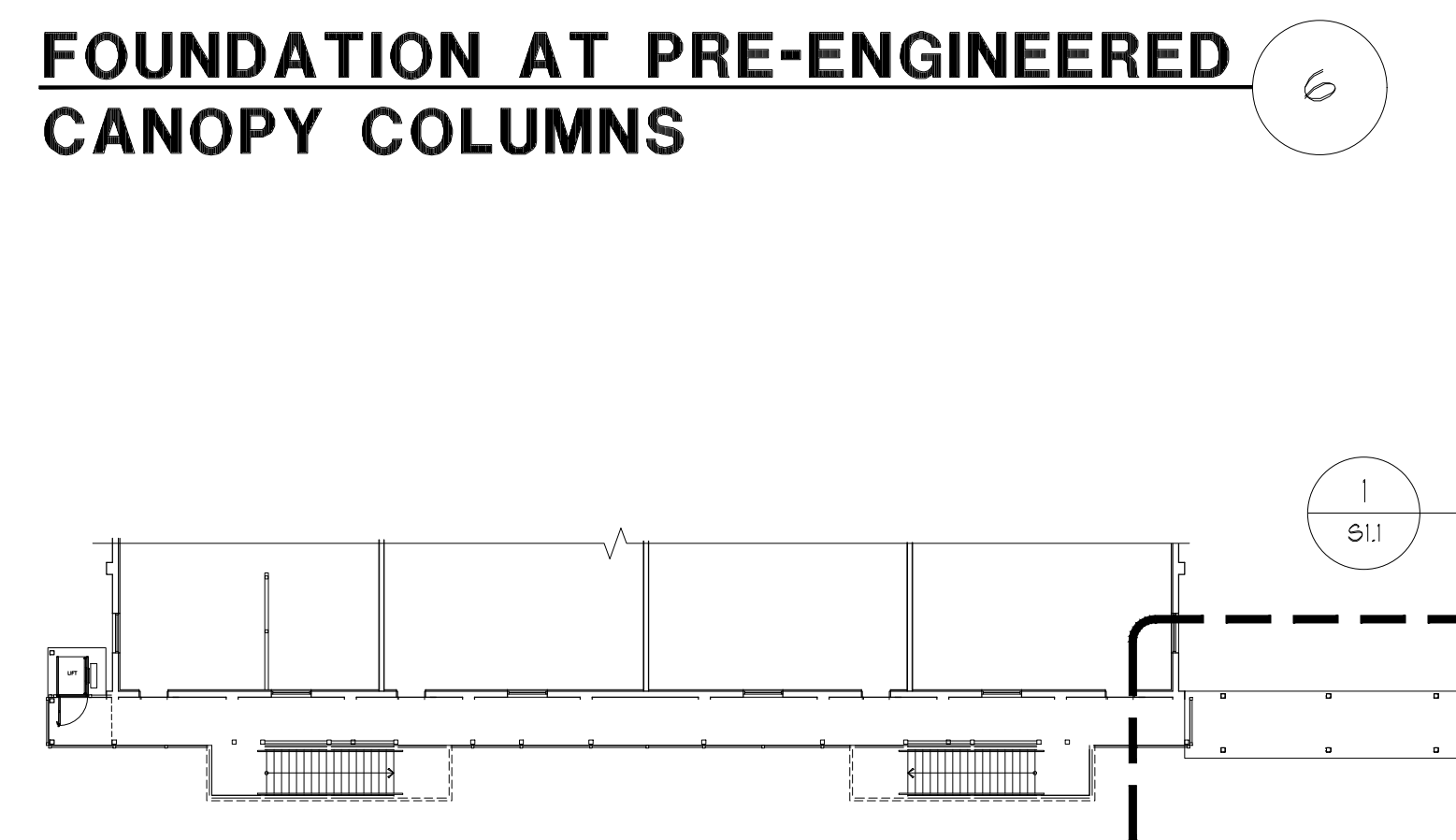
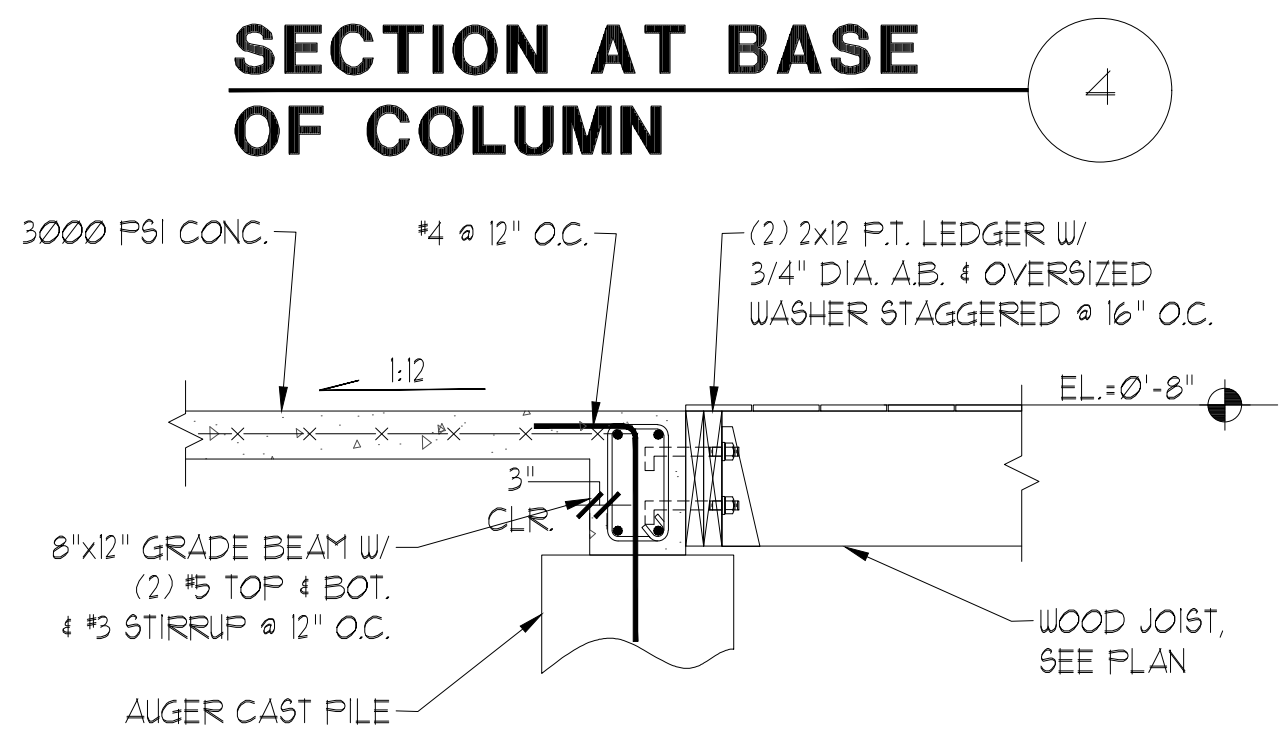
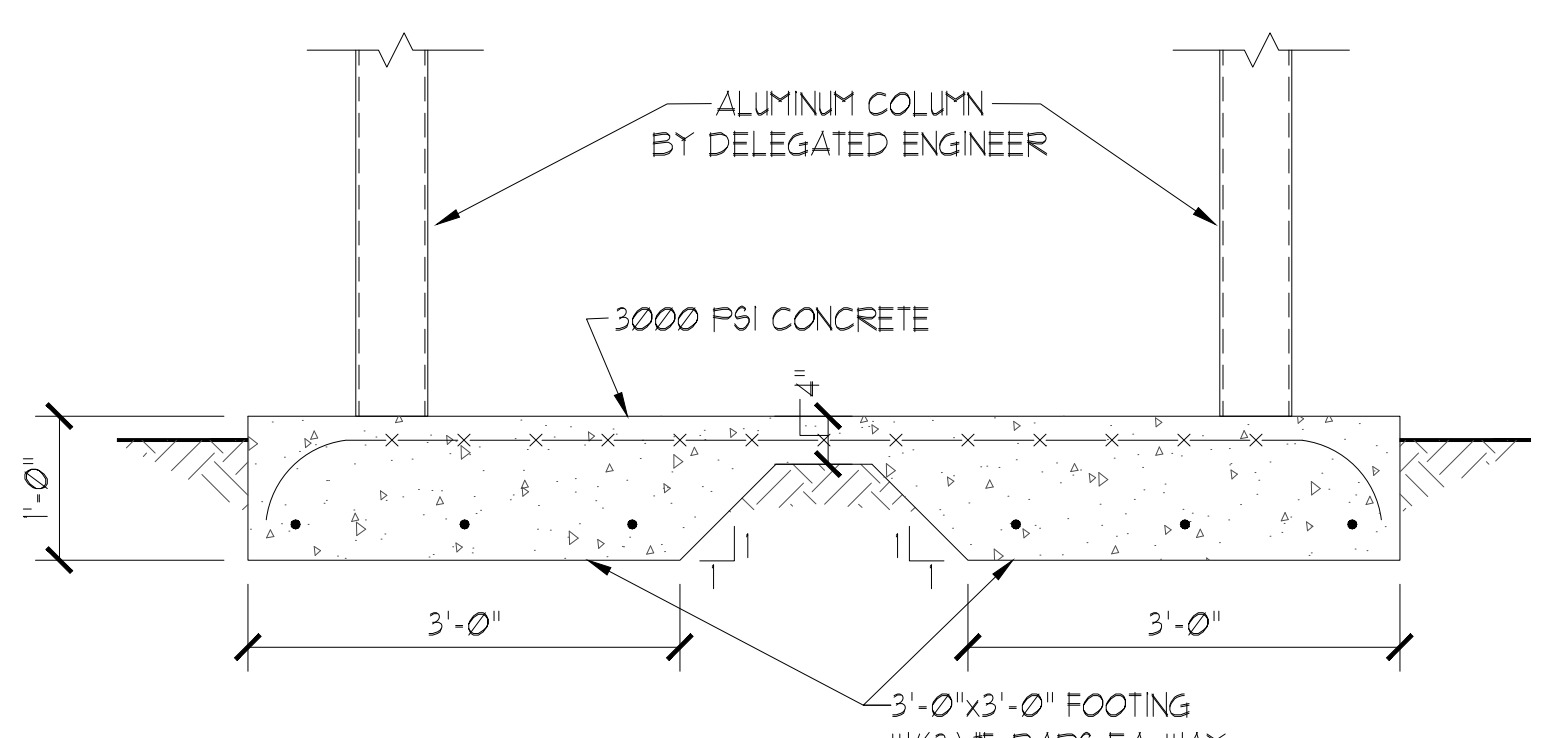
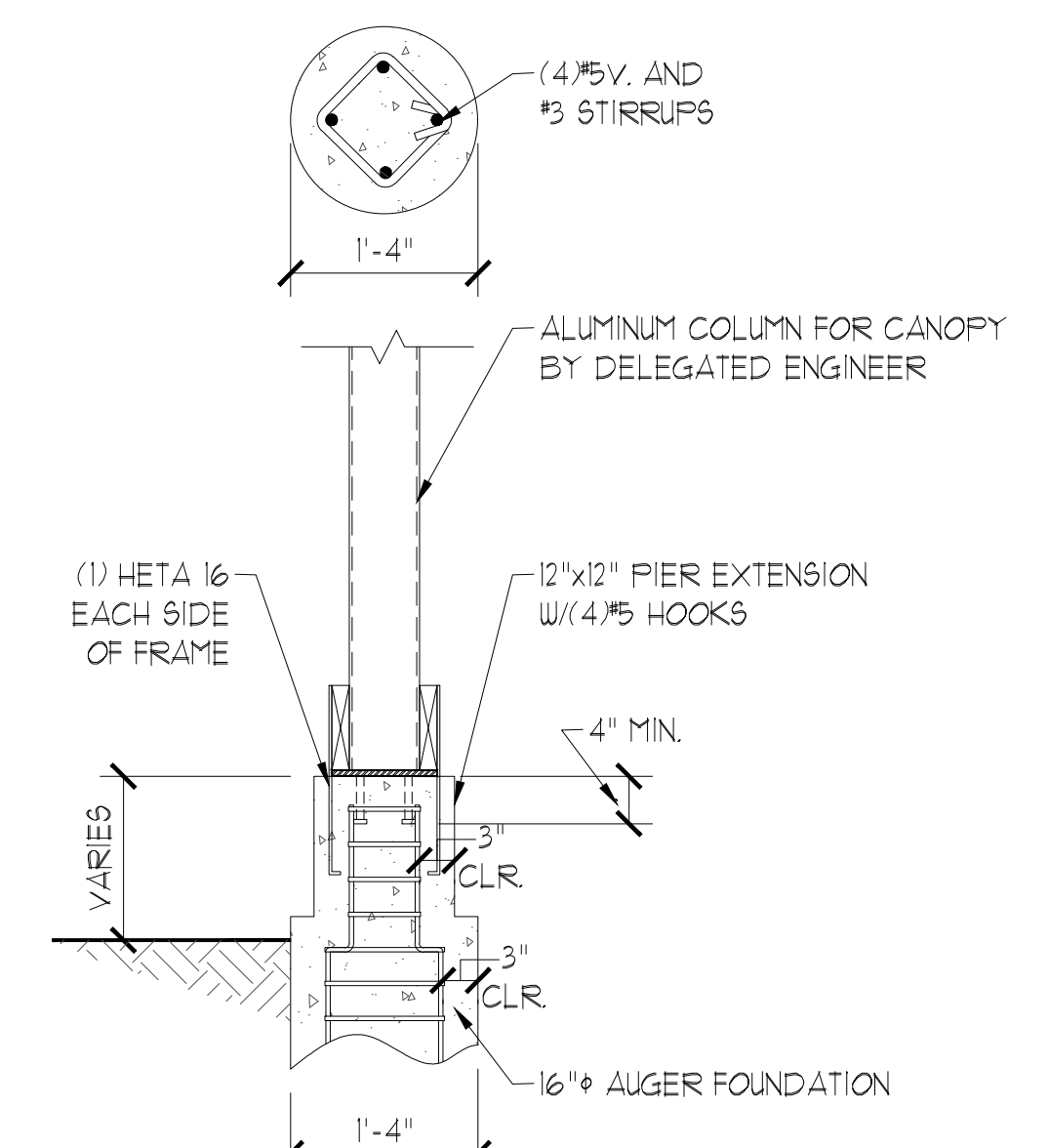
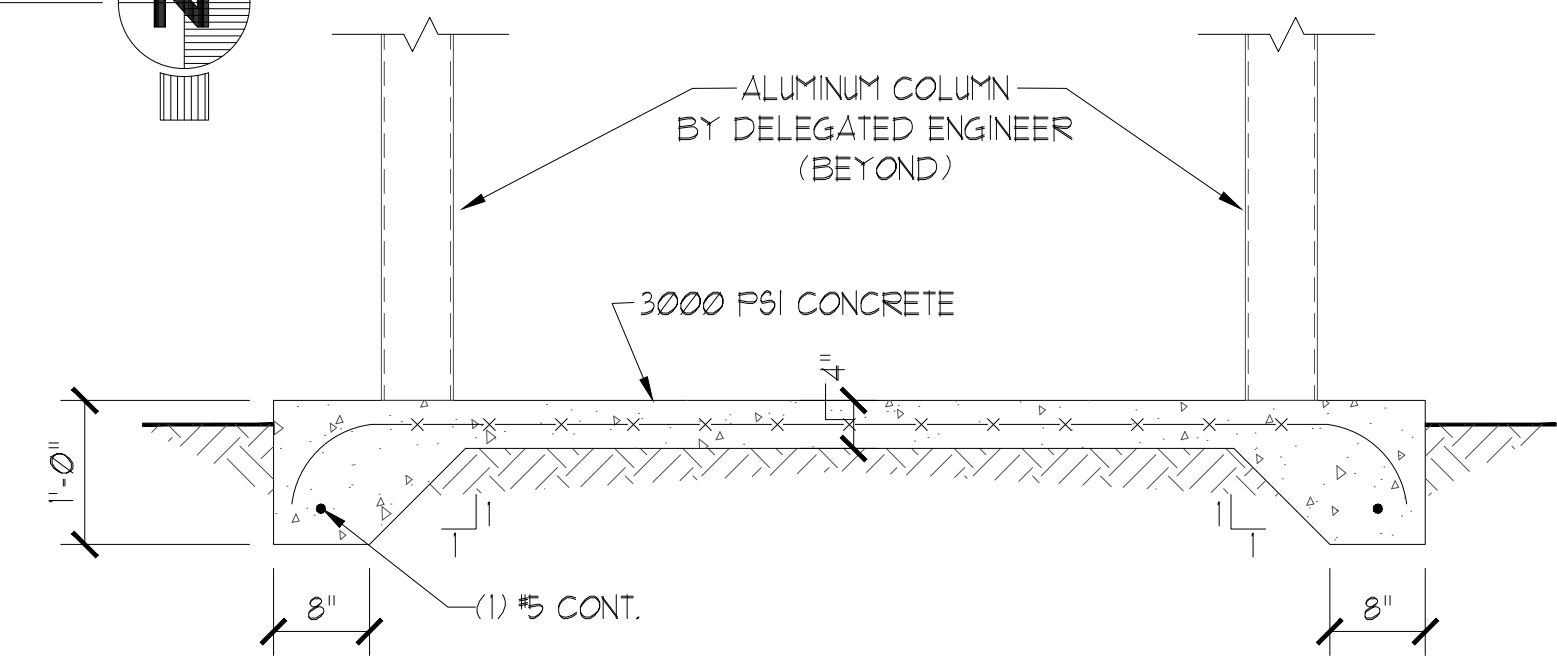
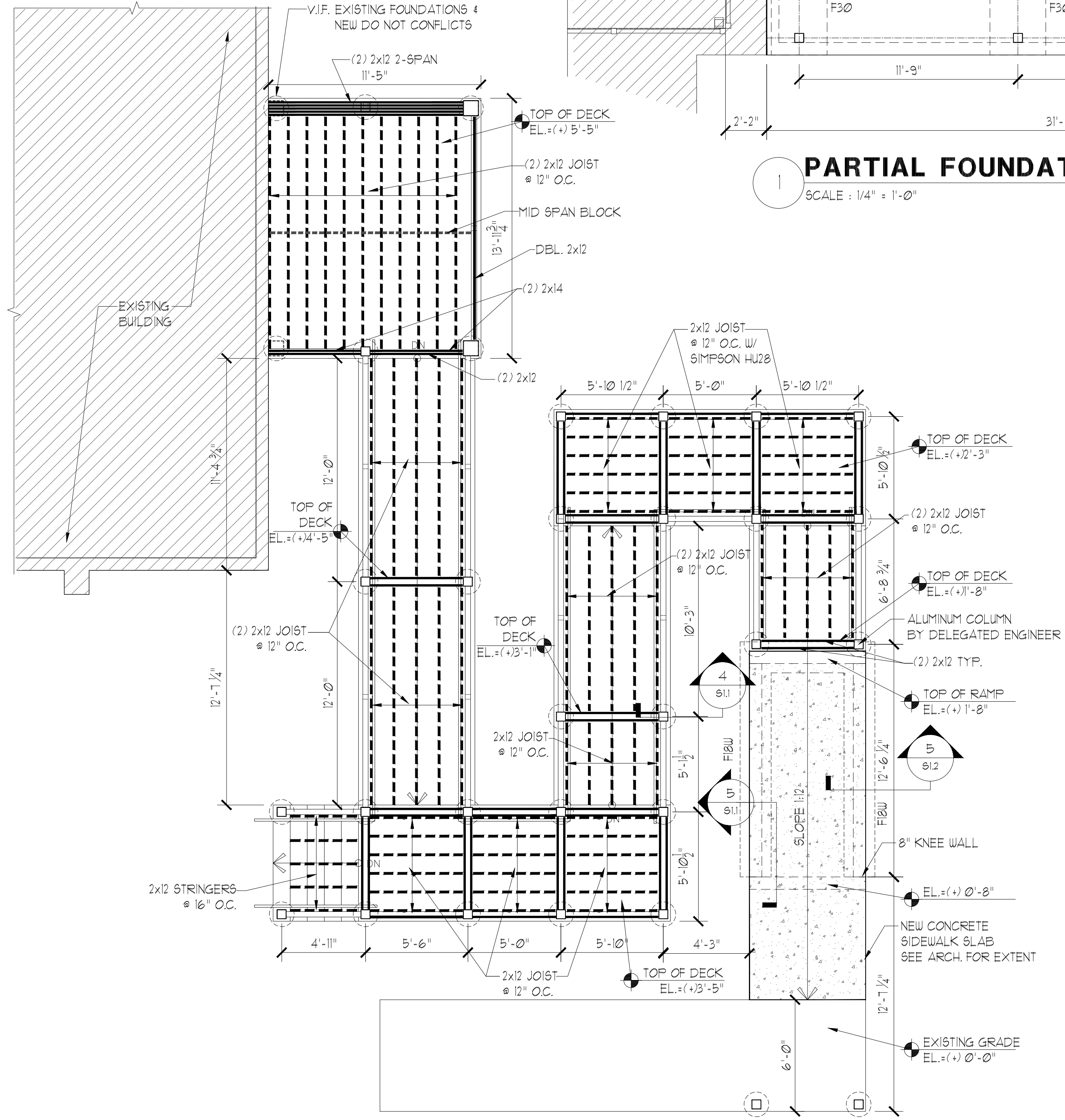
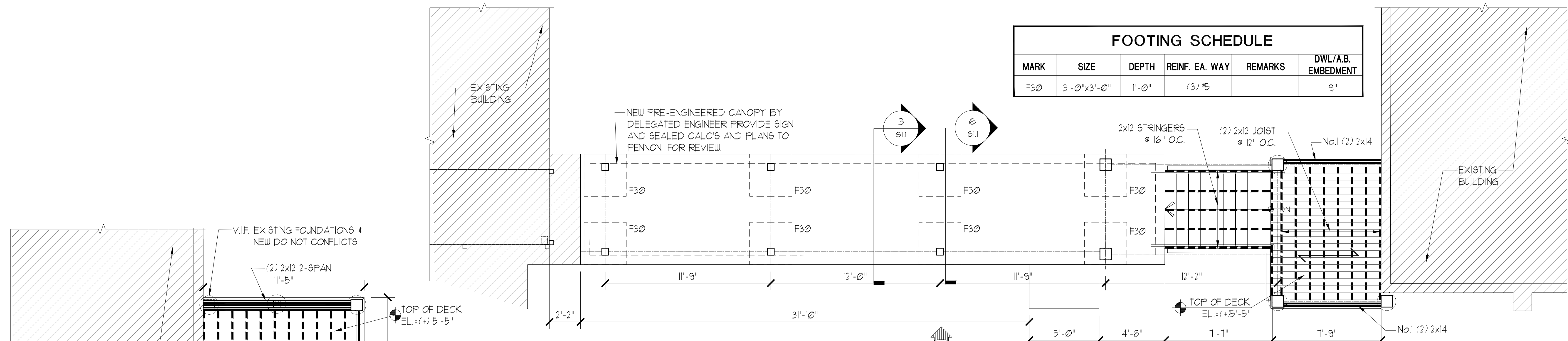

THIS DRAWING IS NOT FOR CONSTRUCTION. IT HAS BEEN ISSUED FOR GOVERNMENTAL REVIEW AND/OR PRELIMINARY PRICING ONLY.

WILLIAM P. HORN ARCHITECT, P.A.

915 EATON ST. KEY WEST, FLORIDA 33040

TEL (305) 296-8302 FAX (305) 296-1033

LICENSE NO. AA 000340

BIG PINE ACADEMY ADA ACCESS COMPLIANCE RENOVATION 30220 OVERSEAS HWY. BIG PINE KEY, FLORIDA

Pennoni
5755 Rio Vista Drive Clearwater, FL 33760-3137 (727) 535-1251 Florida Coa 7819 James Vincent Barnes III, P.E. Florida P.E. 77754 Pennoni Project No. WPHRN20001

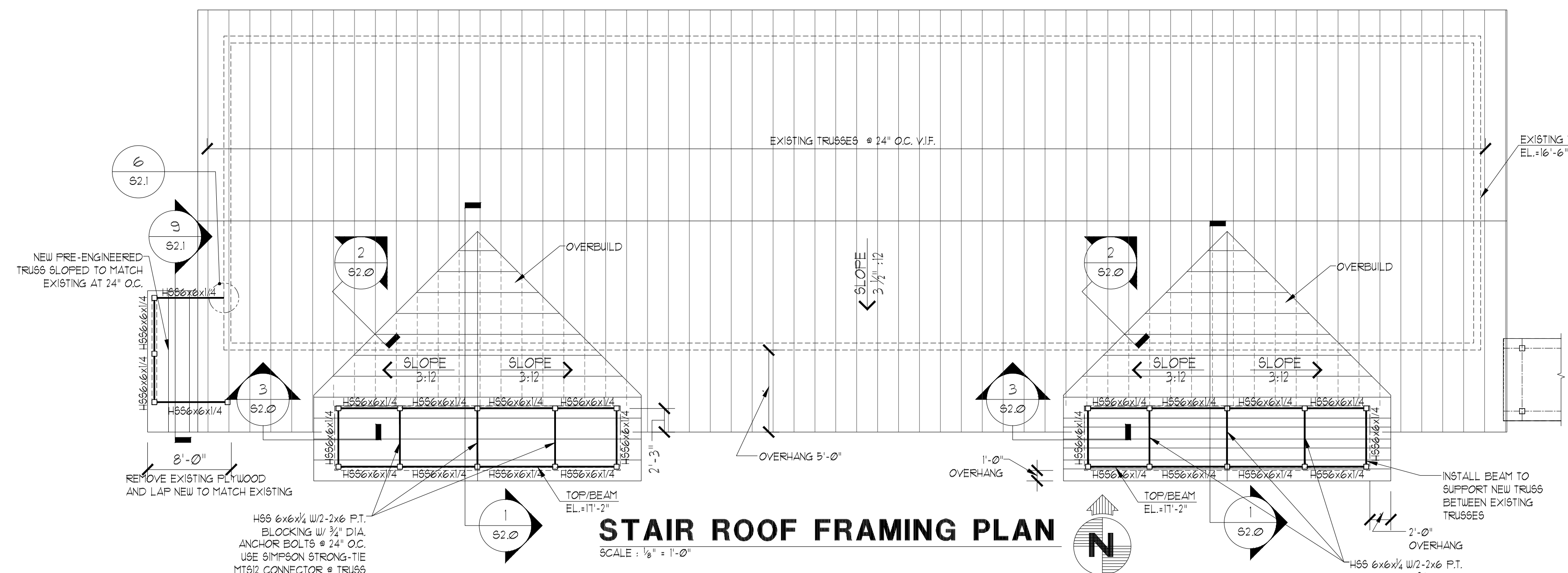

- ROOF PLAN NOTES:**
1. ROOF FRAMING TO BE PRE-ENGINEERED WOOD TRUSSES @ 24" O.C. MAX. SEE ARCH. DRAWINGS FOR EXTENT. PROVIDE SIGNED AND SEALED SHOP DRAWINGS AND CALCULATIONS FOR REVIEW PRIOR TO FABRICATION AND CONSTRUCTION.
 2. ROOF DECK SHEATHING TO BE 3/4" THICK PLYWOOD W/ 6d NAILS @ 4" O.C. AT PANEL EDGES AND 8" O.C. AT INTERMEDIATE SUPPORTS. PROVIDE BLOCKING AT ALL PANEL JOINTS. SEE DETAILS X X FOR ADDITIONAL INFORMATION.
 3. ——— INDICATES ROOF SLOPE.
 4. ROOF TRUSS ELEVATION - SEE PLAN.
 5. REFER TO SHEETS 801 FOR SPECIFICATIONS.
 6. ALL TRUSS TO TRUSS CONNECTIONS BY DELEGATED ENGINEER.
 7. CONTRACTOR IS RESPONSIBLE FOR ALL TEMPORARY BRACING AND SHORING.
 8. VERIFY ALL DIMENSIONS AND ELEVATIONS W/ ARCH. DRAWINGS.
 9. ALL SIMPSON CONTRACTORS ARE TO BE FULLY NAILED UNO.
 10. ALL EXISTING ROOFING TO BE REMOVED FROM TRUSS OVERBUILD PRIOR TO INSTALLATION.

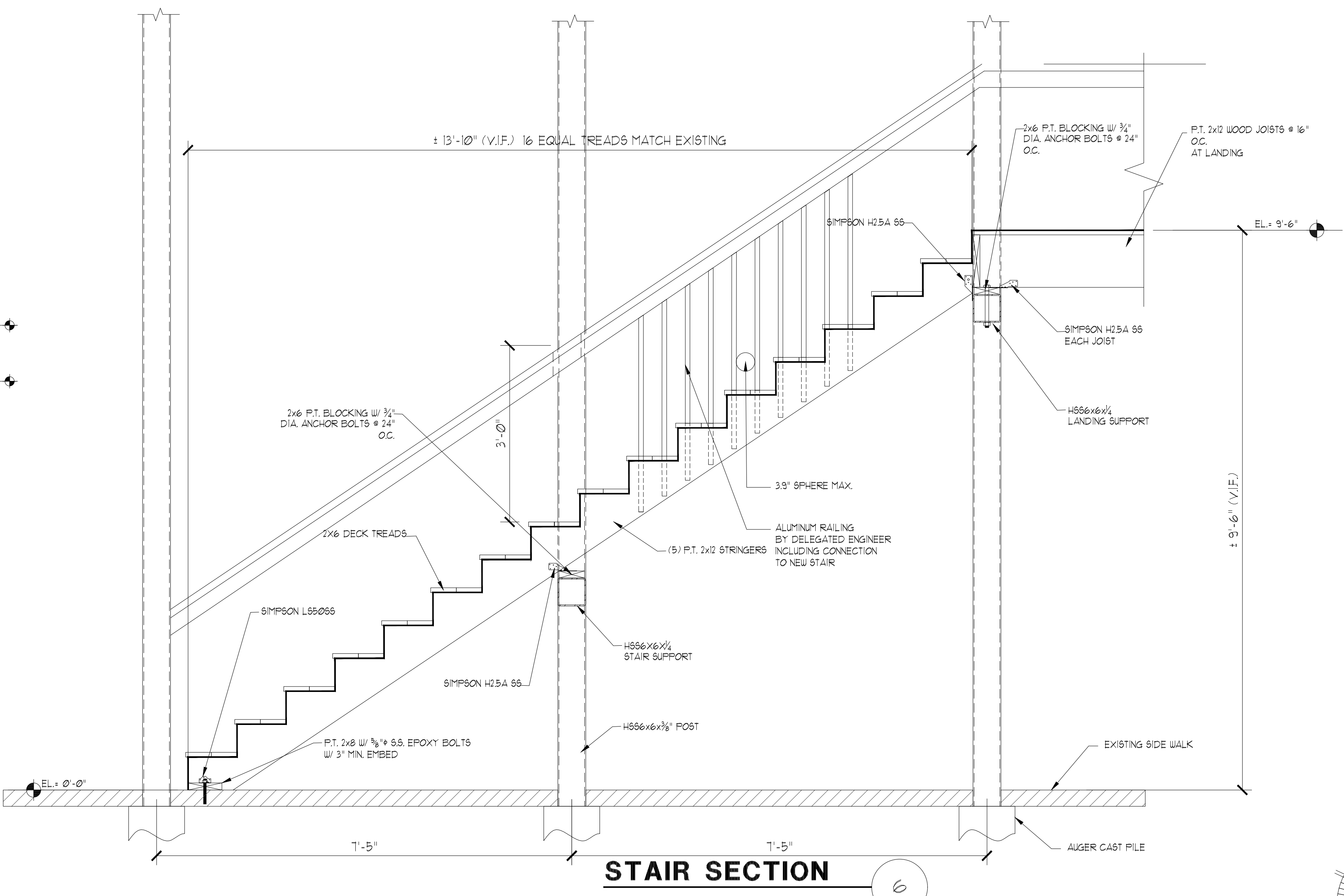
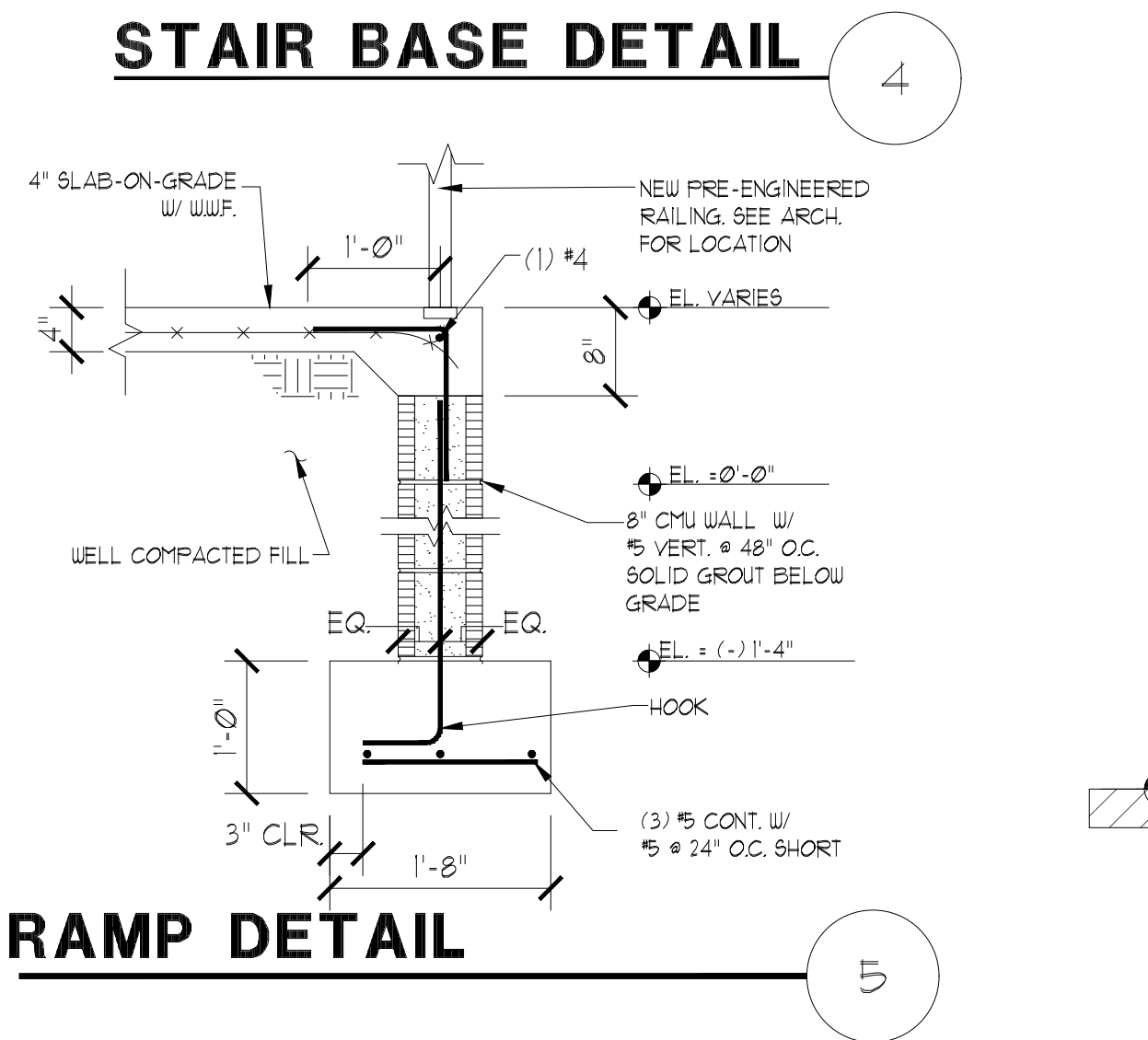
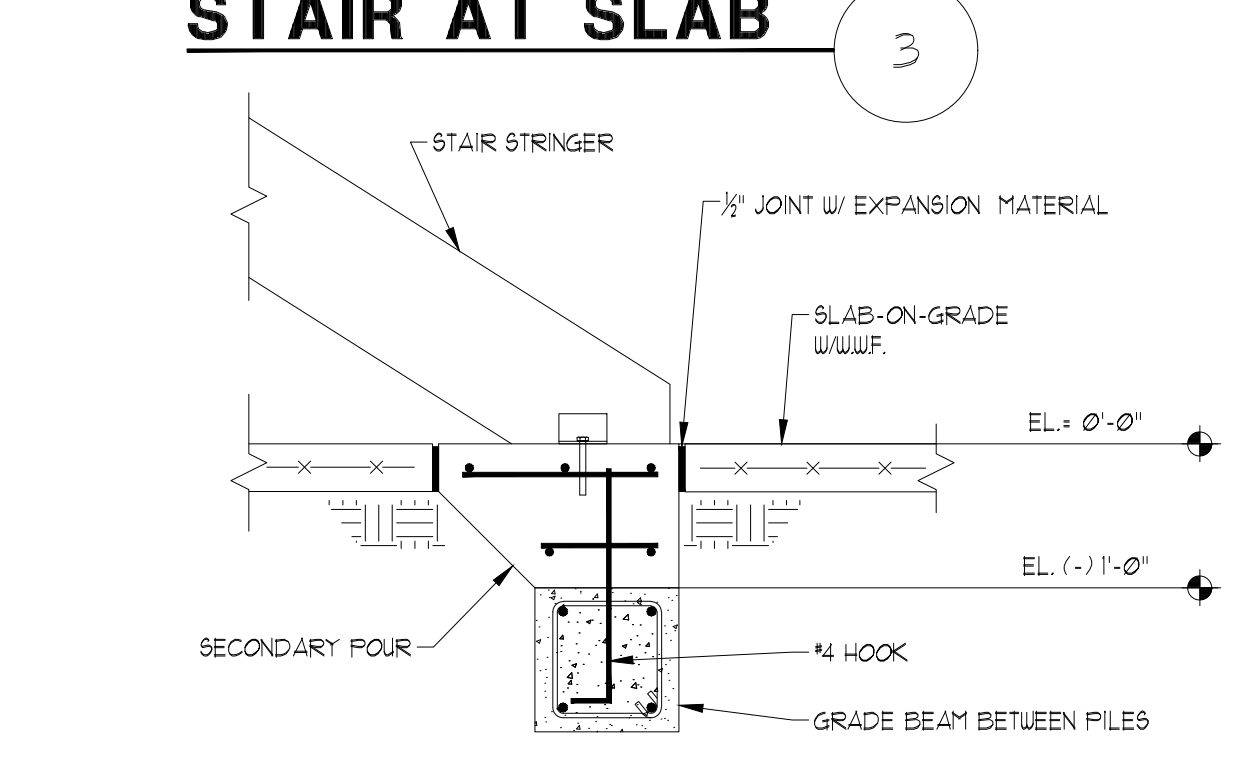
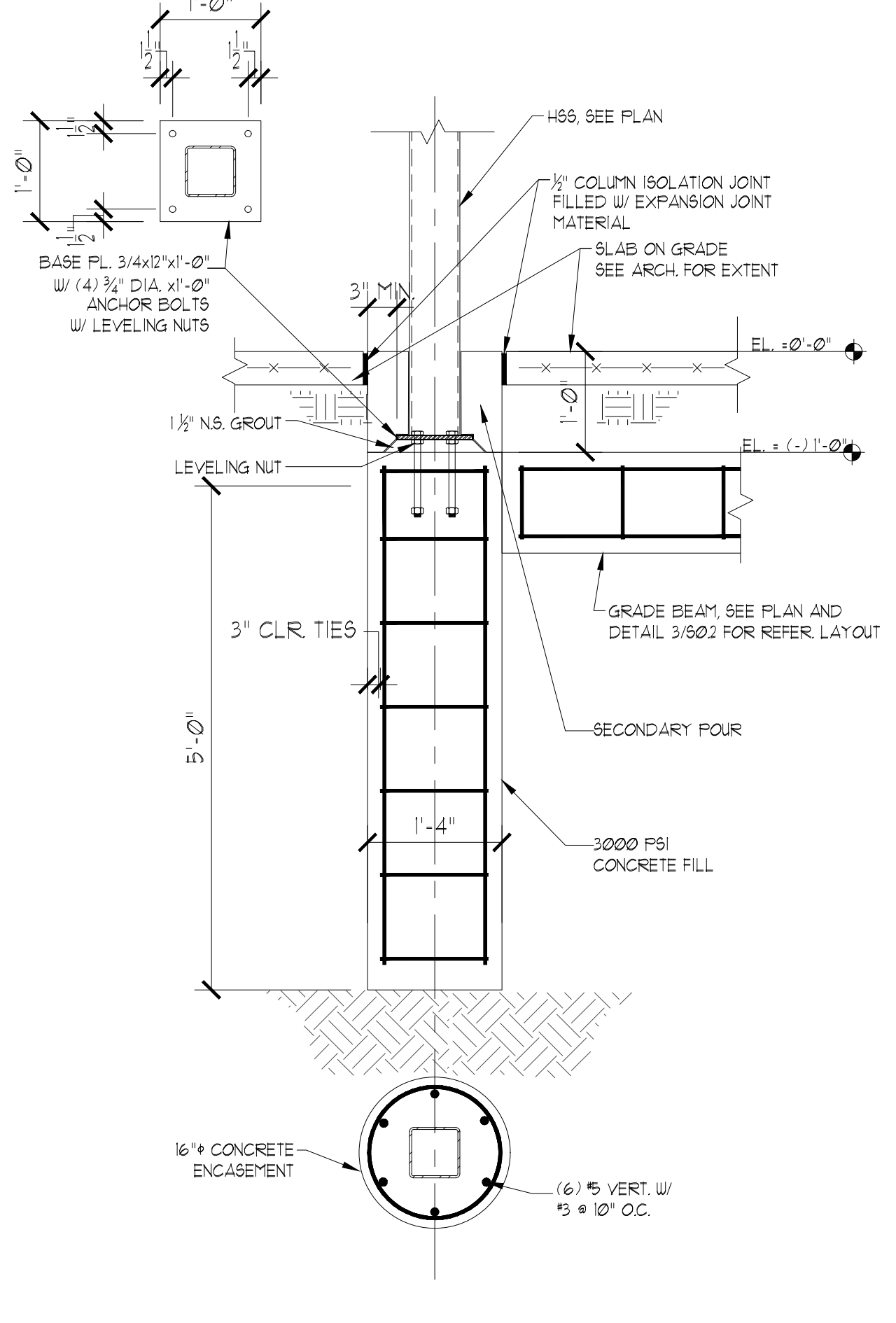
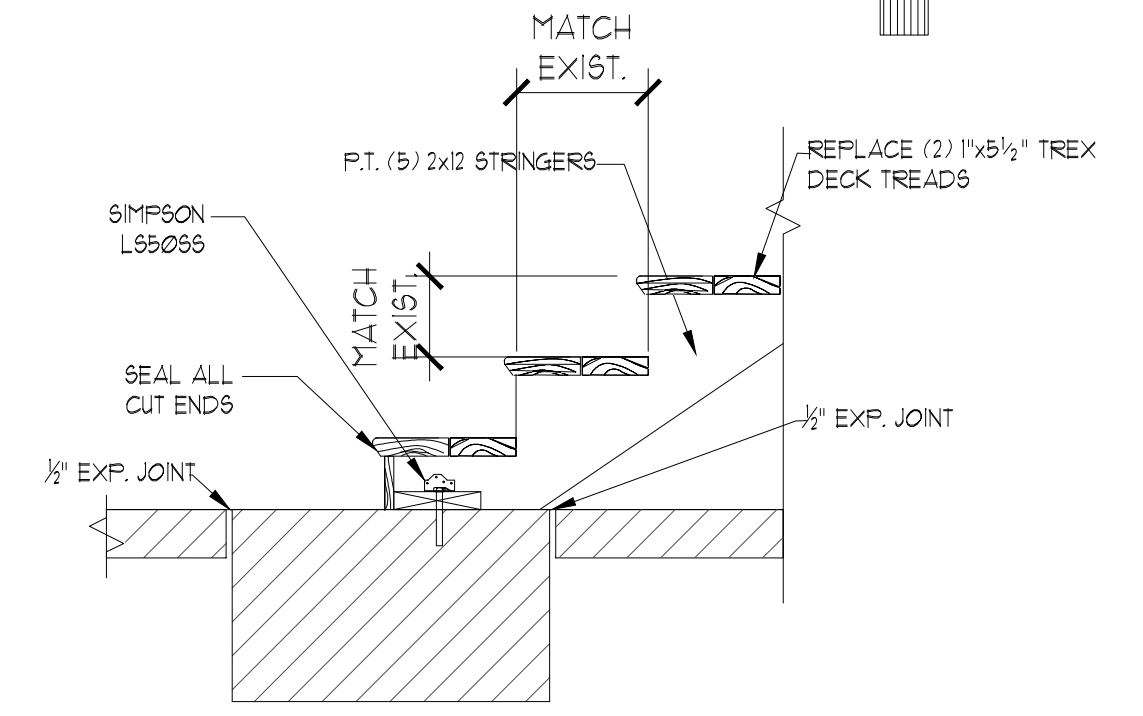
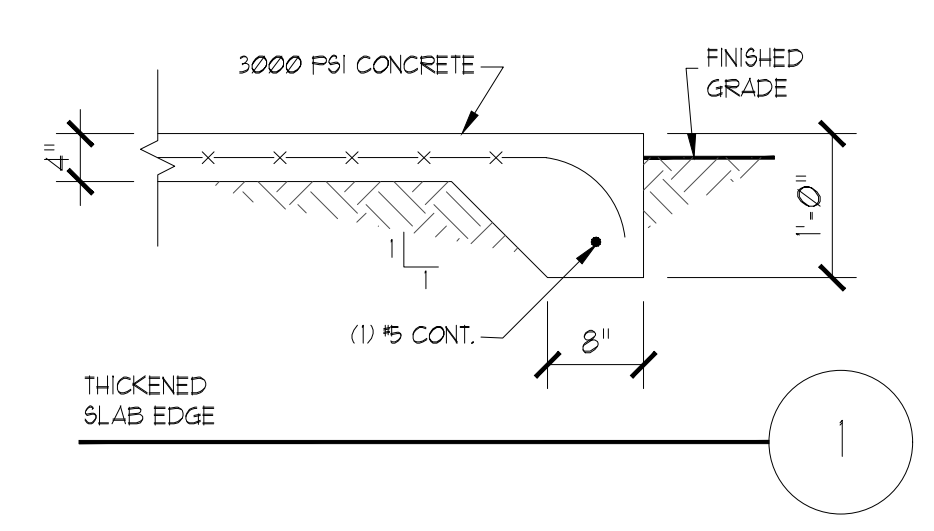
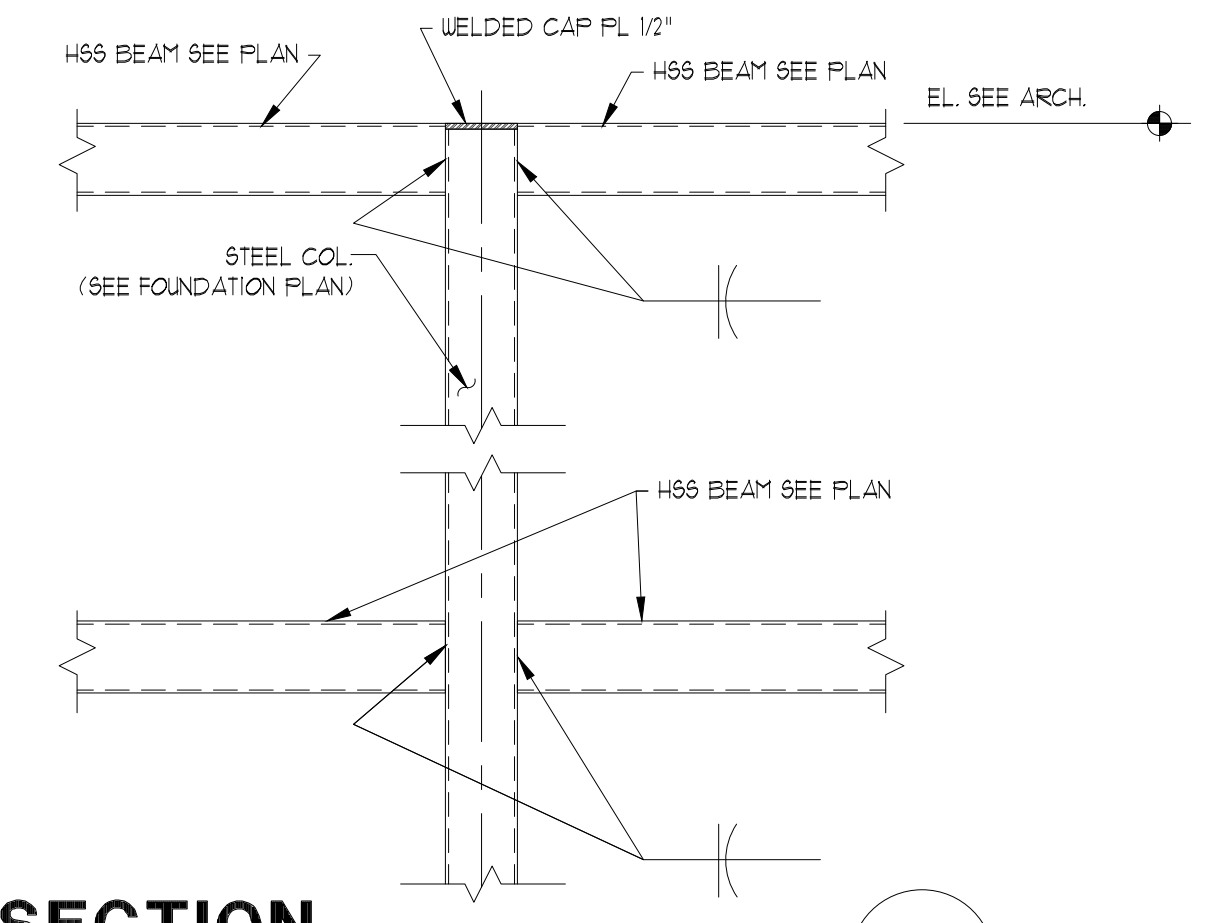

SEAL

DATE 01-28-2022 - BID SET

REVISIONS

DRAWN BY SV

PROJECT NUMBER 2105

NOT FOR CONSTRUCTION - NOT FOR FINAL PRICING - SUBJECT TO CHANGE

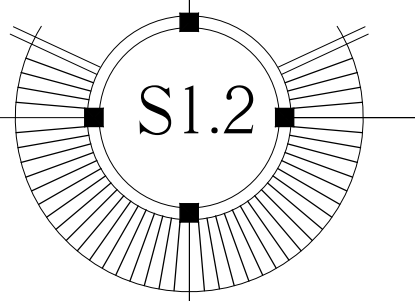

THIS DRAWING IS NOT FOR CONSTRUCTION. IT HAS BEEN ISSUED FOR GOVERNMENTAL REVIEW AND/OR PRELIMINARY PRICING ONLY.

WILLIAM P. HORN
ARCHITECT, P.A.

915 EATON ST.
KEY WEST,
FLORIDA
33040

TEL (305) 296-8302
FAX (305) 296-1033

LICENSE NO.
AA 0003040

BIG PINE ACADEMY
ADA ACCESS
COMPLIANCE
RENOVATION
30220 OVERSEAS HWY.
BIG PINE KEY, FLORIDA

Pennoni
5755 Rio Vista Drive
Clearwater, FL 33760-3137
(727) 535-1251
Florida Coa 7819
James Vincent Barnes III, P.E.
Florida P.E. 77754
Pennoni Project No. WPHRN20001

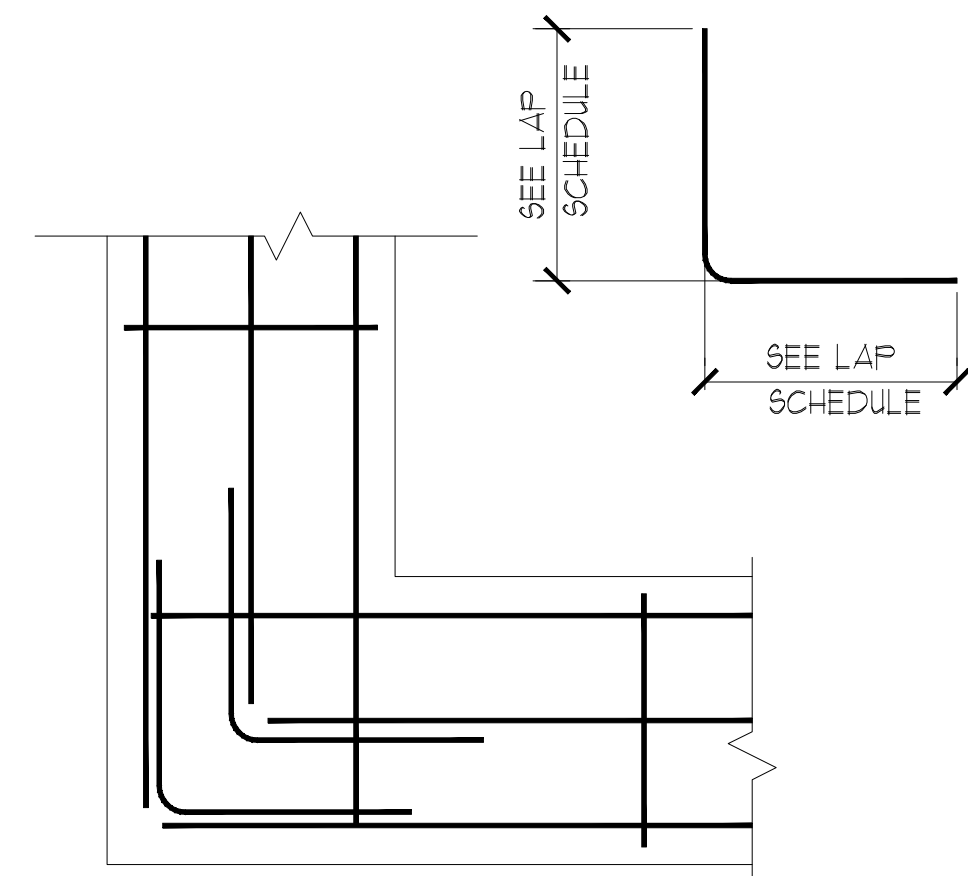

CORNER BAR DETAIL AT FOUNDATION 1

CONCRETE COLUMN LAP SCHEDULE		
4000 PSI NORMAL WGT. CONC.		
BAR SIZE	COMPRESSION LAP	TENSION LAP CLASS "B"
#5 BAR	25"	32"
#6 BAR	30"	38"
#7 BAR	35"	54"
#8 BAR	40"	62"
#9 BAR	45"	70"
#10 BAR	50"	80"
#11 BAR	55"	88"

CONCRETE COLUMN LAP SCHEDULE 2

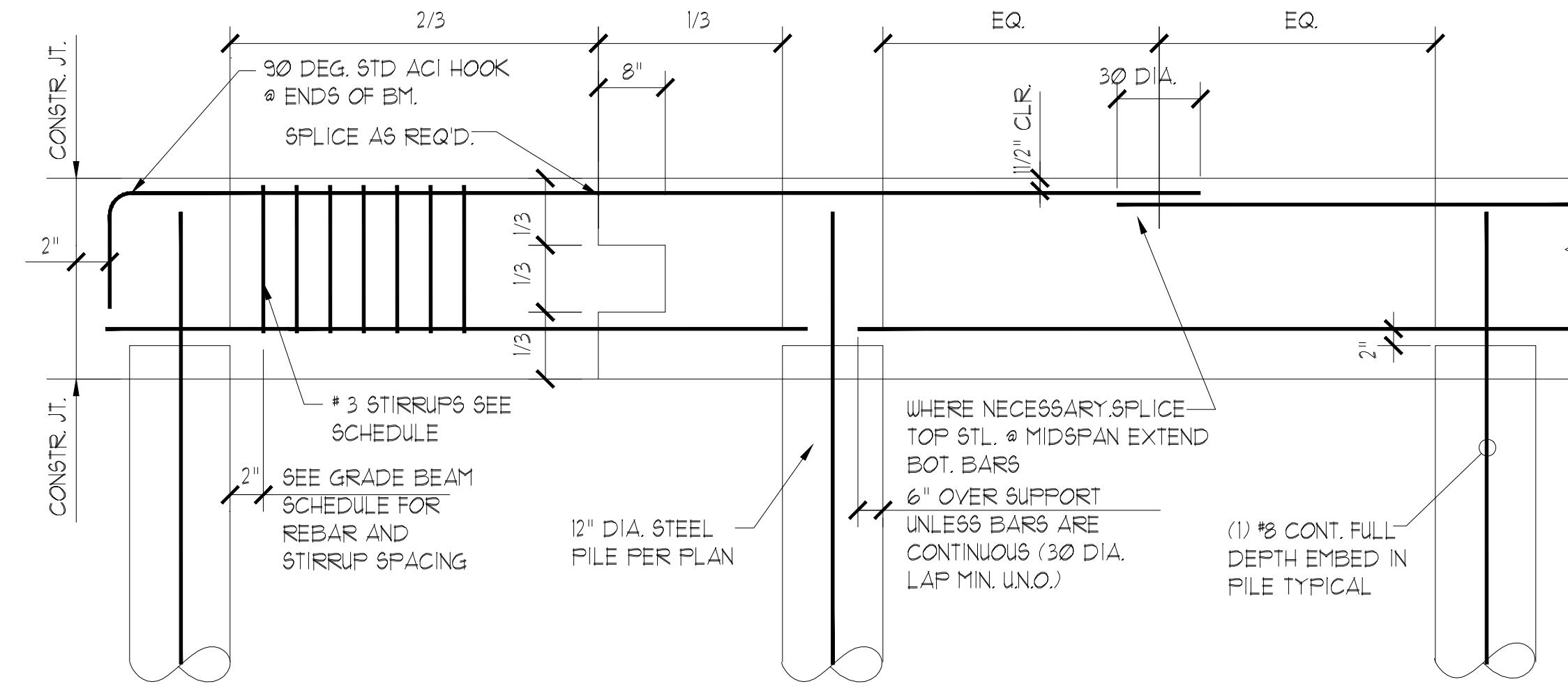

GRADE BEAM REINFORCING 3

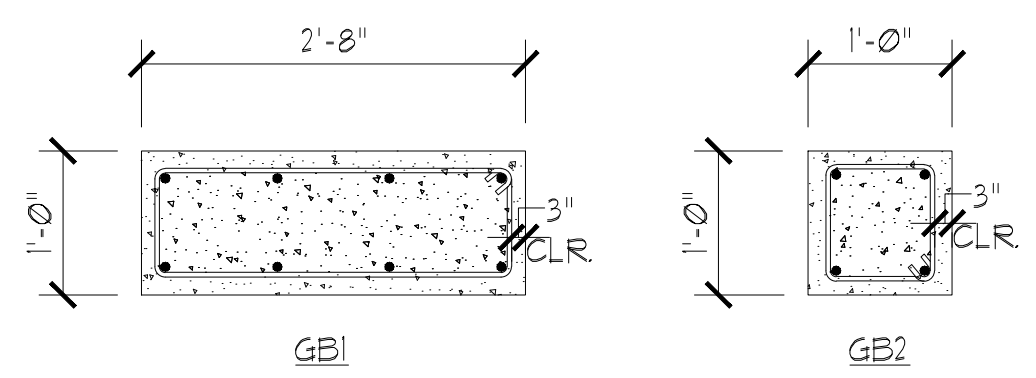

GRADE BEAM LEGEND		
MARK	DIMENSION	REINFORCING
GB1	12"D. x 32"W.	(4) #5 T.4B. & #3 STIRRUPS @ 12" O.C.
GB2	12"D. x 12"W.	(2) #5 T.4B. & #3 STIRRUPS @ 12" O.C.

GRADE BEAM 4

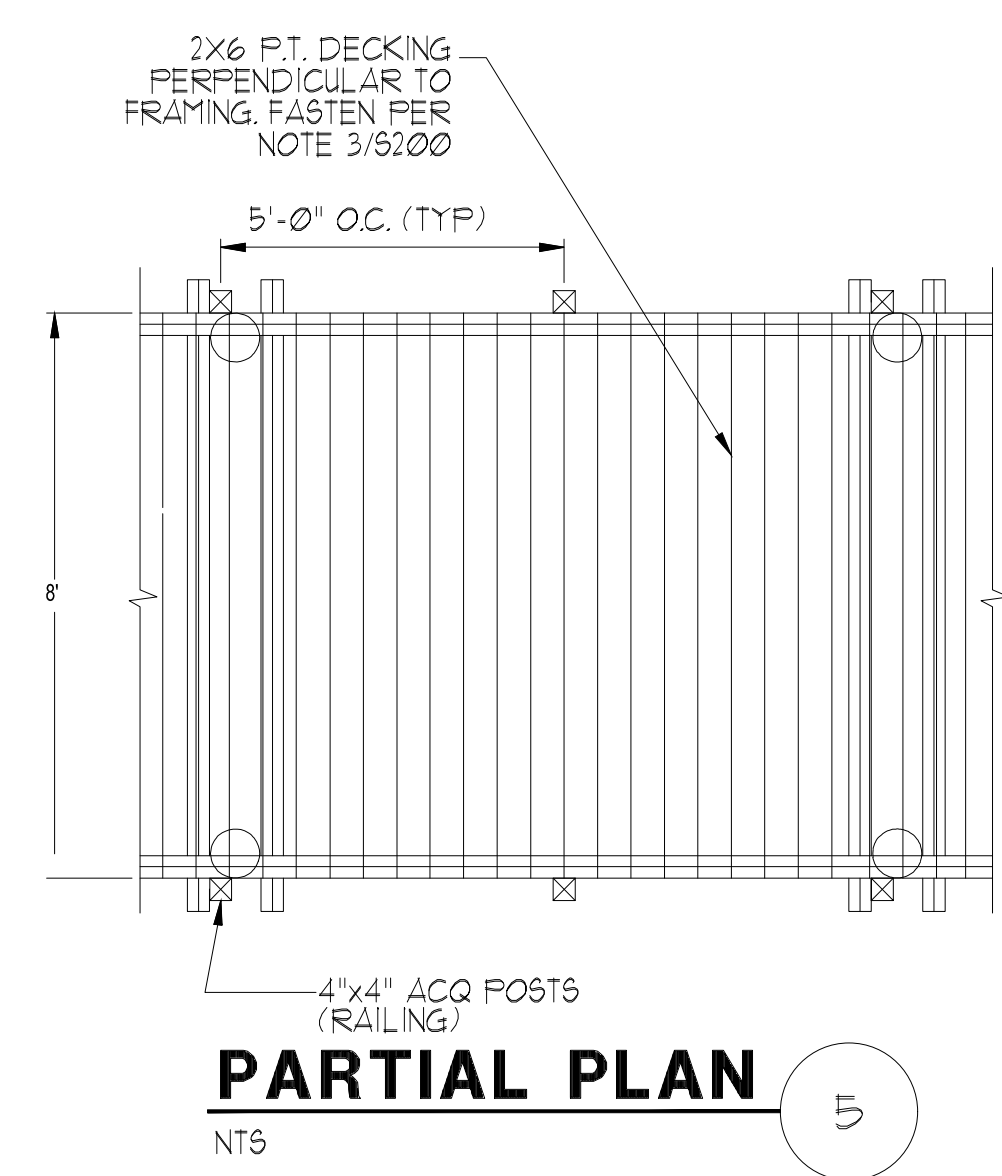

PARTIAL PLAN 5

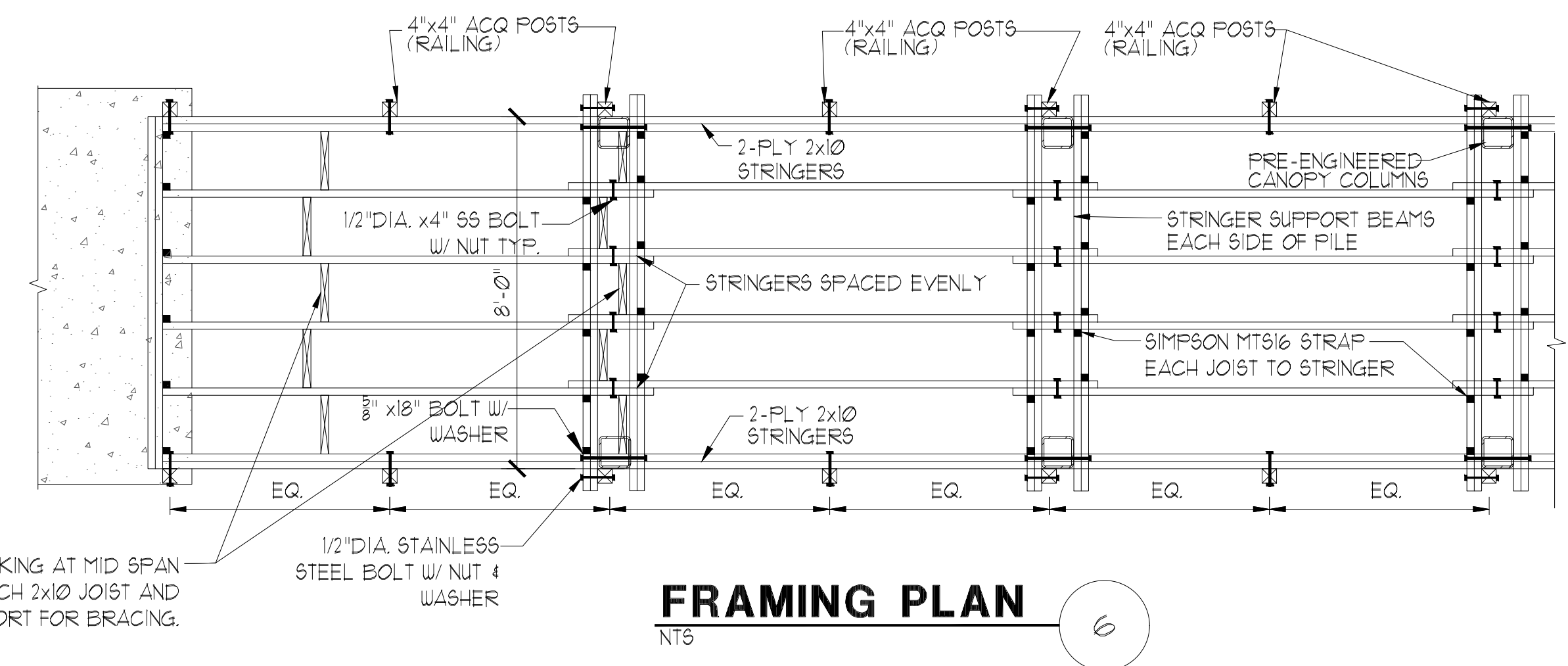

FRAMING PLAN 6

SEAL _____

NOT FOR CONSTRUCTION - NOT FOR FINAL PRICING - SUBJECT TO CHANGE

DATE
01-28-2022 - BID SET

REVISIONS _____

DRAWN BY
SV

PROJECT NUMBER
2105

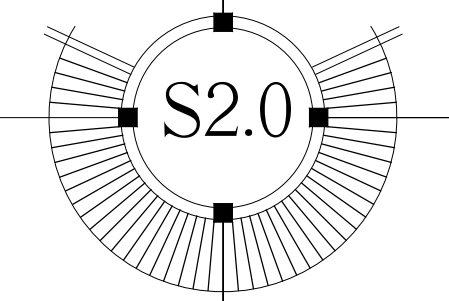

THIS DRAWING IS NOT FOR CONSTRUCTION. IT HAS BEEN ISSUED FOR GOVERNMENTAL REVIEW AND/OR PRELIMINARY PRICING ONLY.

WILLIAM P. HORN ARCHITECT, P.A.

915 EATON ST. KEY WEST, FLORIDA 33040

TEL (305) 296-8302 FAX (305) 296-1033

LICENSE NO. AA 0003040

BIG PINE ACADEMY ADA ACCESS COMPLIANCE RENOVATION 30220 OVERSEAS HWY. BIG PINE KEY, FLORIDA



5755 Rio Vista Drive Clearwater, FL 33760-3137 (727) 535-1251 Florida P.E. 77754 Pennoni Project No. WPHRN20001

SEAL

NOT FOR CONSTRUCTION - NOT FOR FINAL PRICING - SUBJECT TO CHANGE

DATE 01-28-2022 - BID SET

REVISIONS

DRAWN BY SV

PROJECT NUMBER 2105

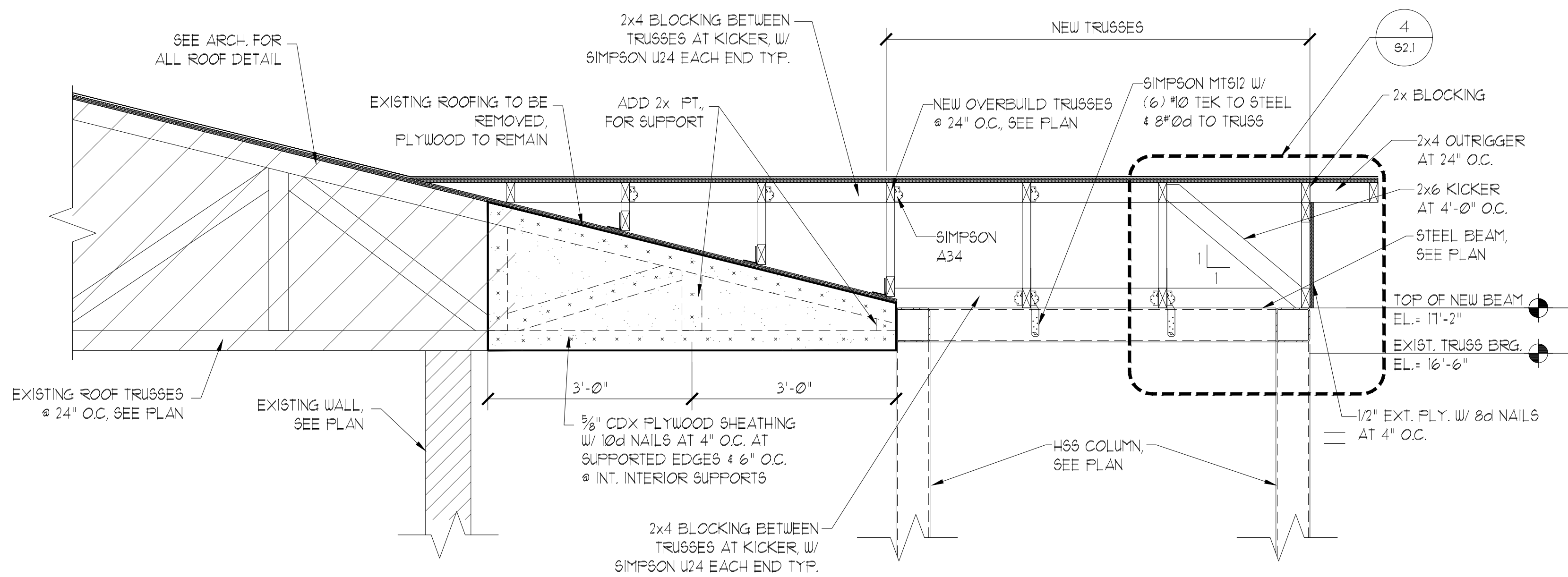

MODIFIED TRUSS SECTION

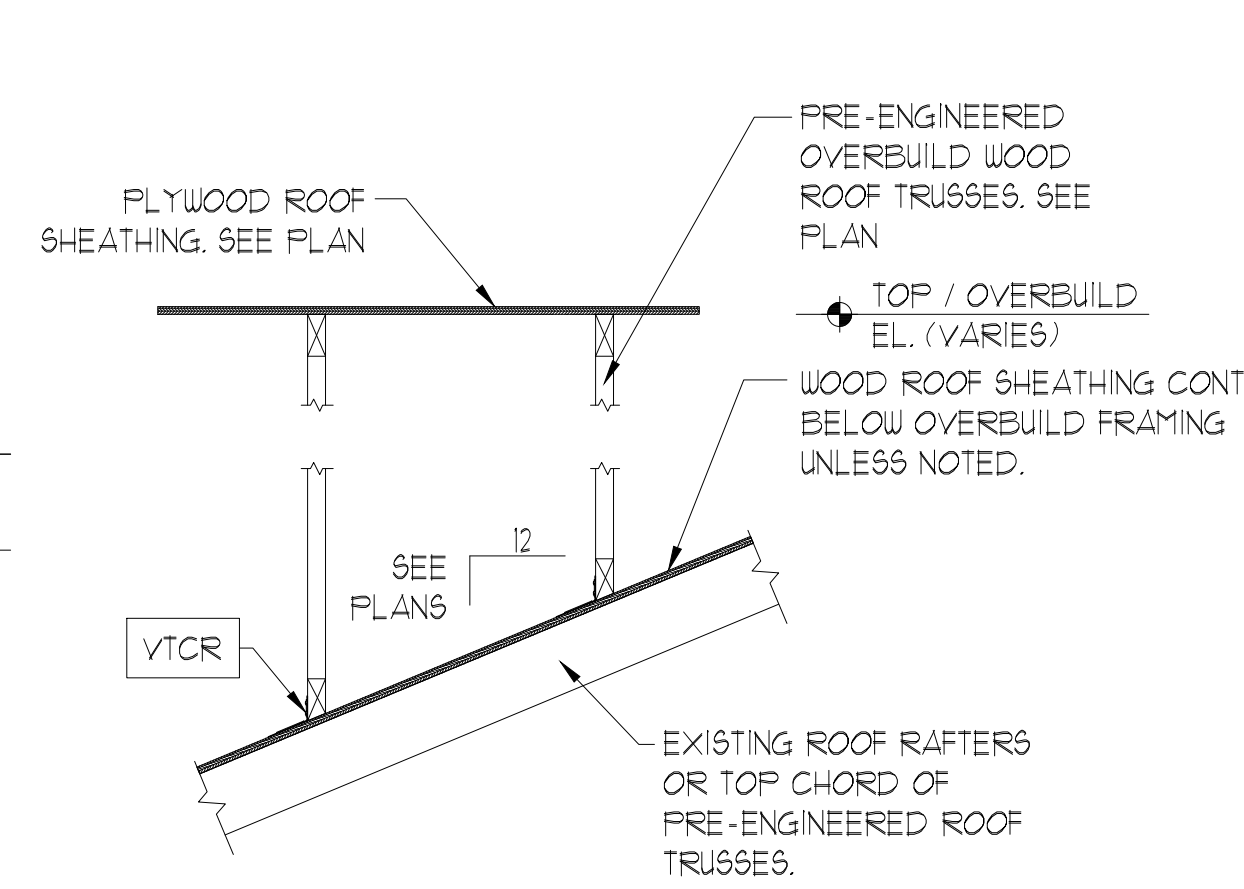

OVER BUILT TRUSS CONNECTION

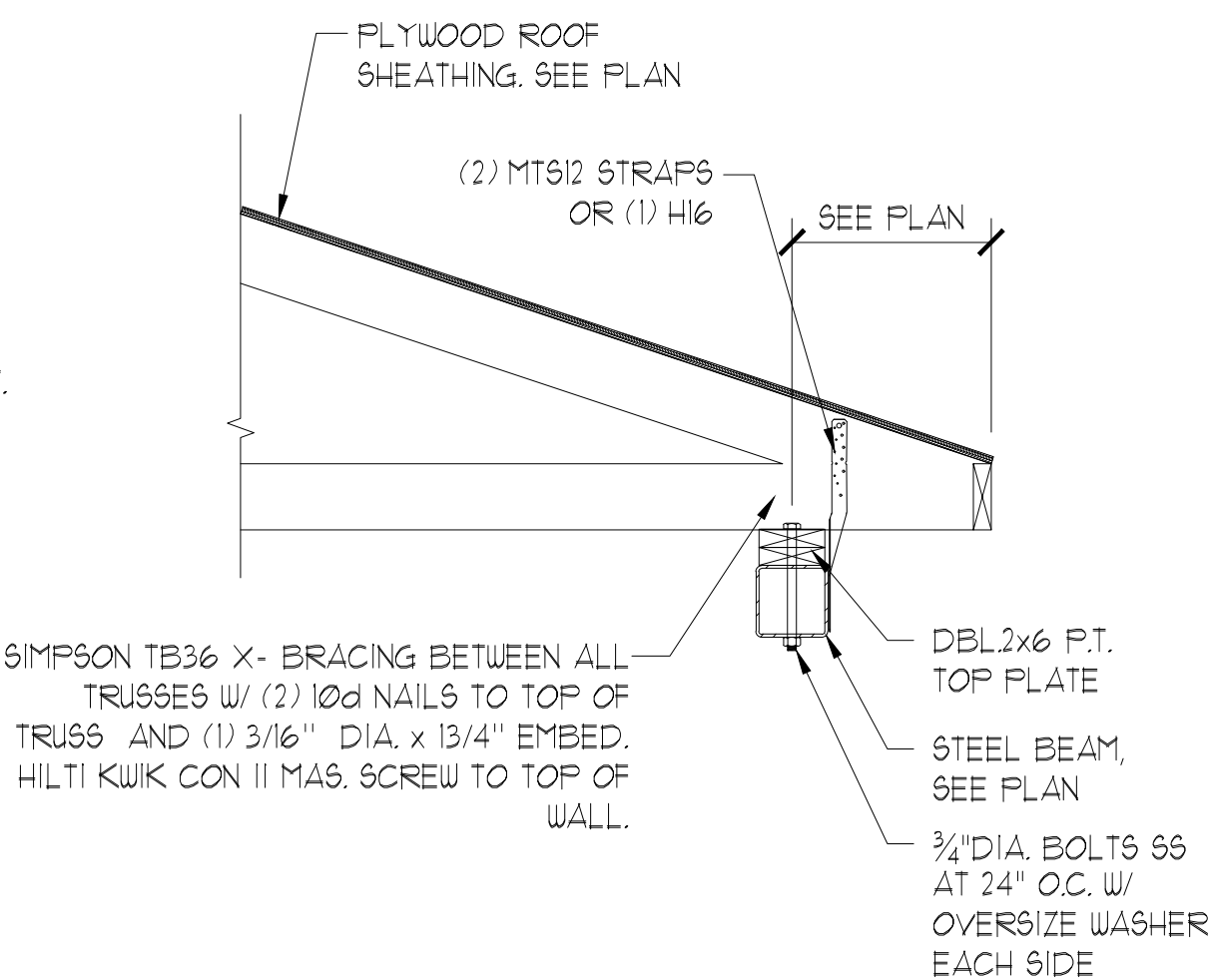

TRUSS BEARING

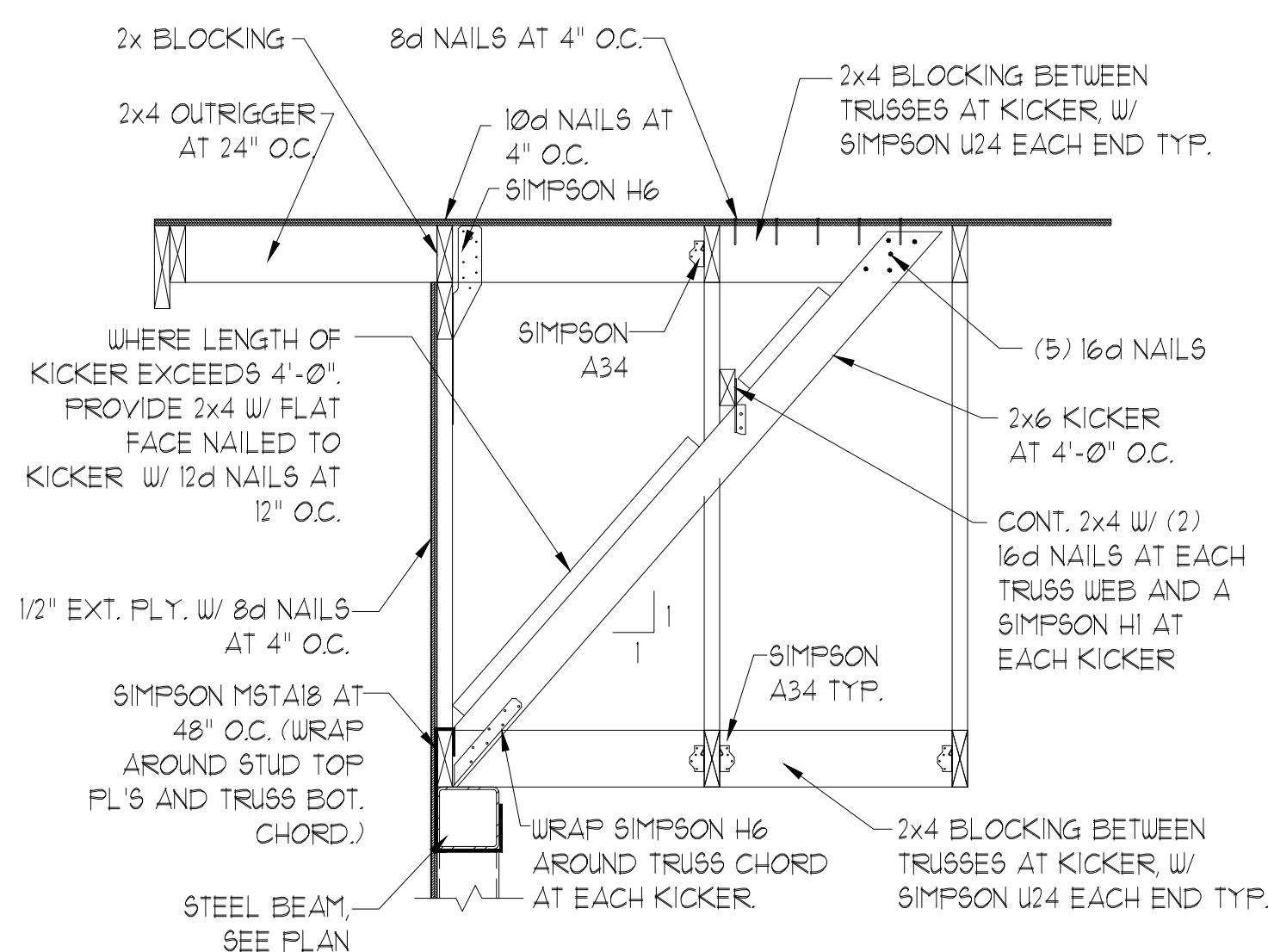

TYPICAL SECTION AT GABLE END TRUSSES

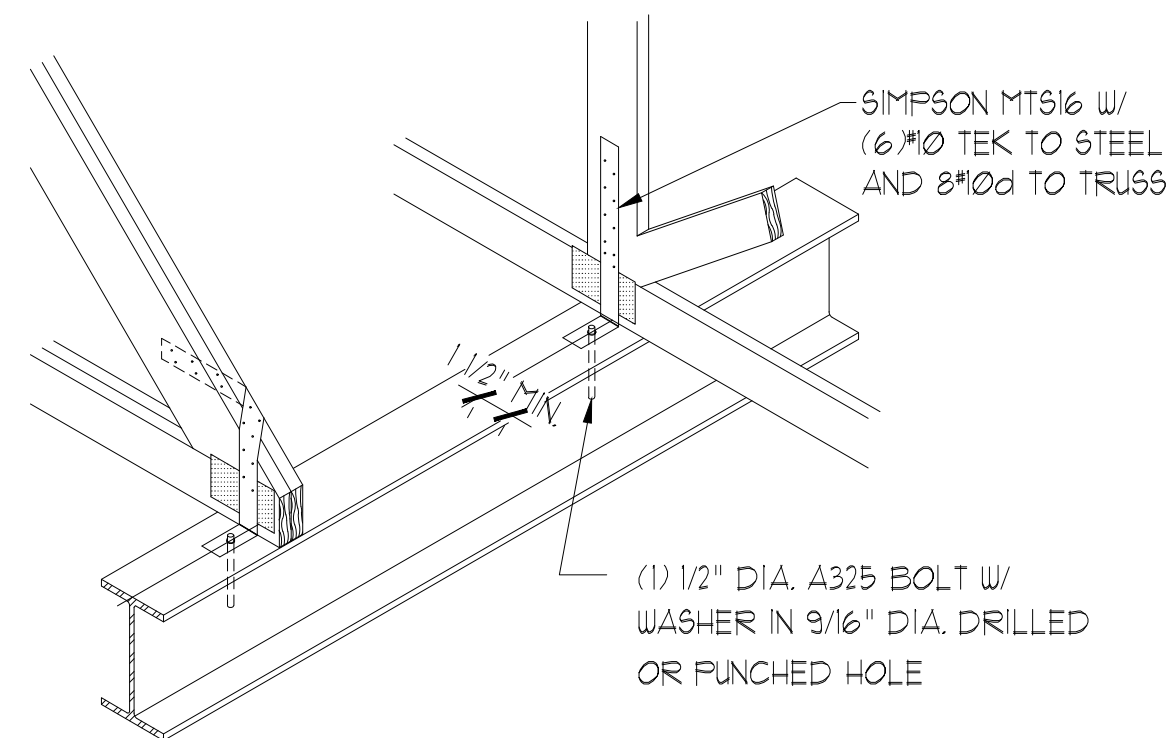

TYPICAL TRUSS-TO-STEEL CONNECTION (ALTERNATE)

SCALE: 1/2" = 1'-0"

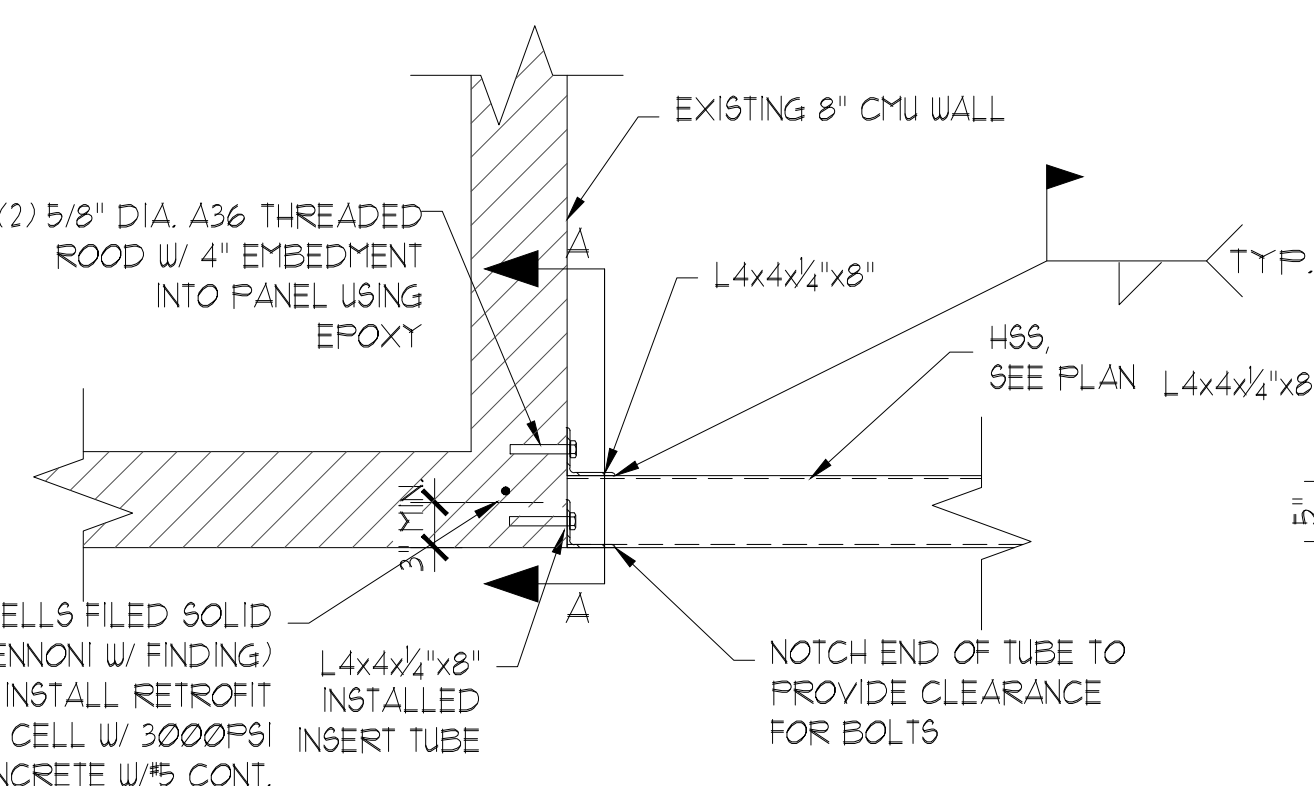

CONNECTION DETAIL AT SOUTH ELEVATION ENTRANCE STOREFRONT

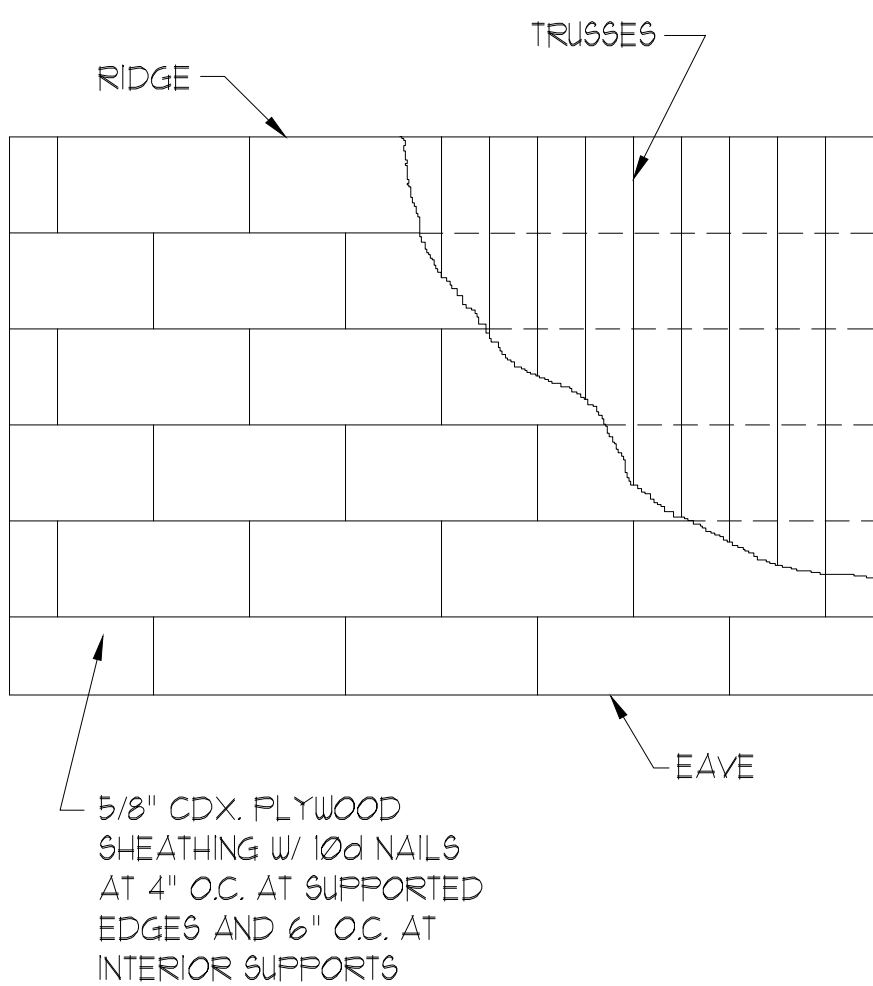

PLYWOOD ROOF DIAPHRAGM

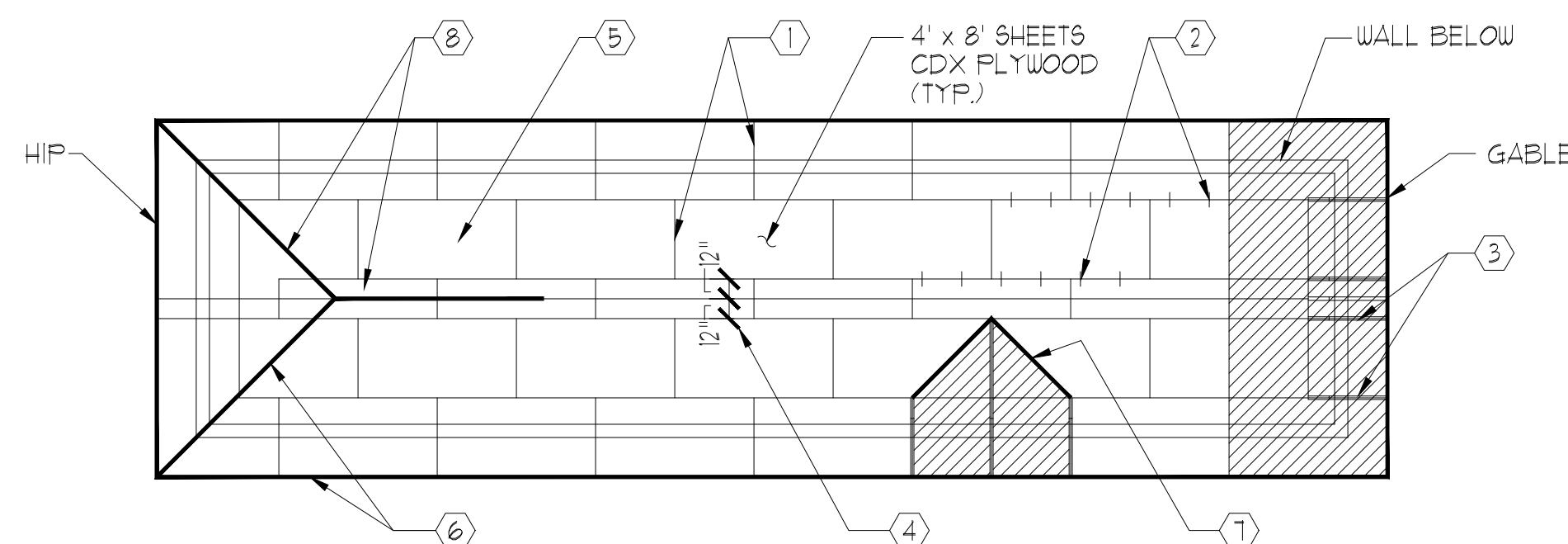

- ① STAGGER END JOINTS AT FRAMING MEMBER
- ② PROVIDE A HURRICANE CLIP AT EACH JOINT, BETWEEN EACH FRAMING MEMBER
- ③ 2x4 BLOCKING AT EACH JOINT, IN END ZONE
- ④ MINIMUM PLYWOOD WIDTH 12". SEE ARCHITECT FOR RIDGE VENTS 1/2" OR LESS PLYWOOD - 8d COMMONS AT 4" O.C. EDGES 6" O.C. INTERMEDIATE
- ⑤ 5/8" OR GREATER PLYWOOD - 10d COMMONS AT 4" O.C. EDGES 6" O.C. INTERMEDIATE
- ⑥ NAILING 6" O.C. AT HIP'S AND SUBFASCIA W/ 8d COMMON.
- ⑦ NAILING 3" O.C. AT VALLEYS W/ 8d COMMON.
- ⑧ PROVIDE BEVELED WOOD SHIMS FOR PLYWOOD BEARING.
- ⑨ WHERE MEAN ROOF HEIGHT EXCEEDS 25'-0", USE RING SHANK NAILS.

ROOF DIAGRAM NAILING SCHEDULE

SCALE: 1/8" = 1'-0"

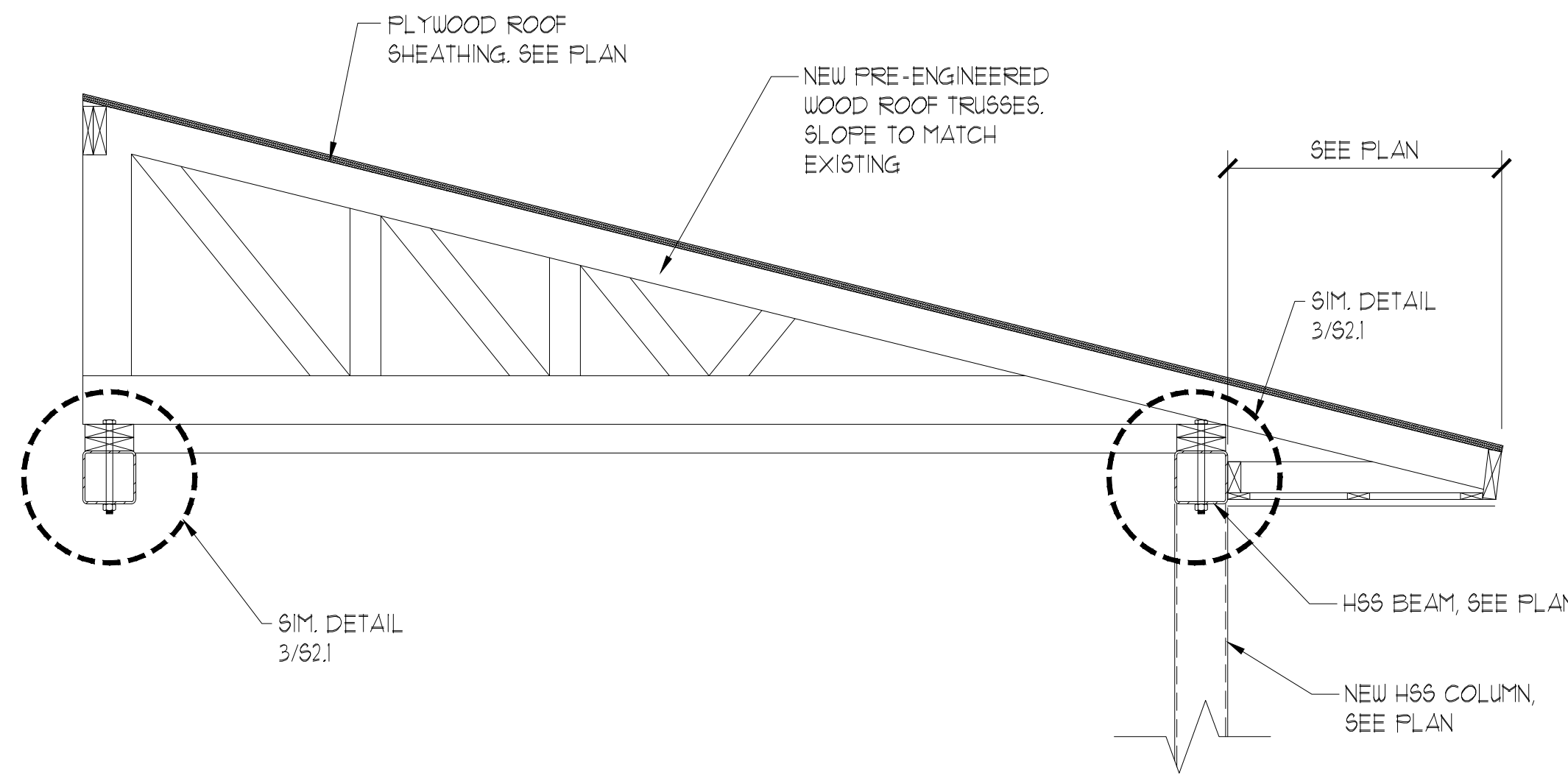

TRUSS SECTION

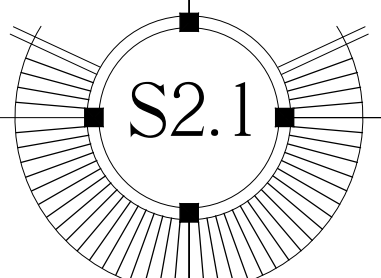

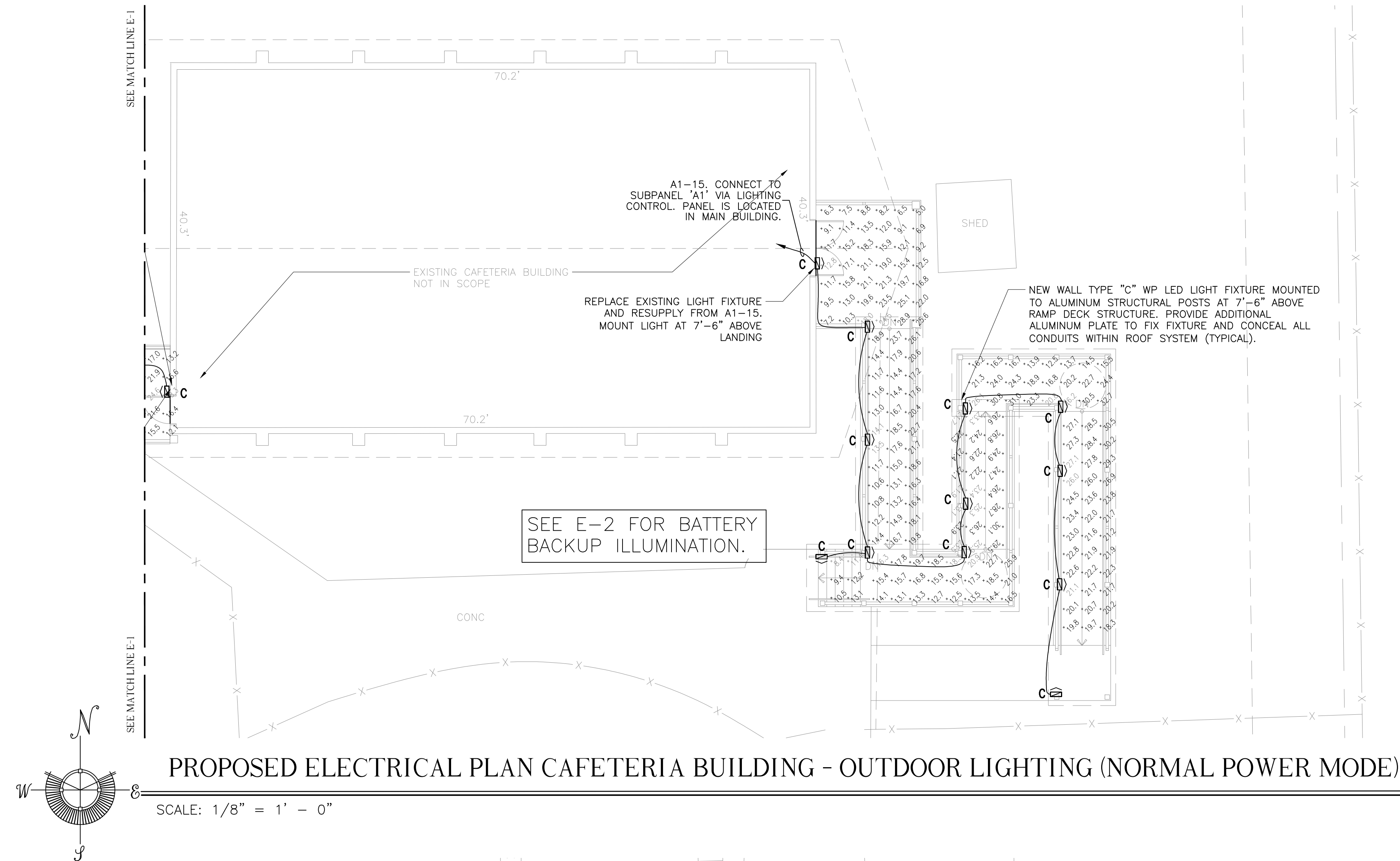

PROPOSED ELECTRICAL PLAN CAFETERIA BUILDING - OUTDOOR LIGHTING (NORMAL POWER MODE)

SCALE: 1/8" = 1' - 0"

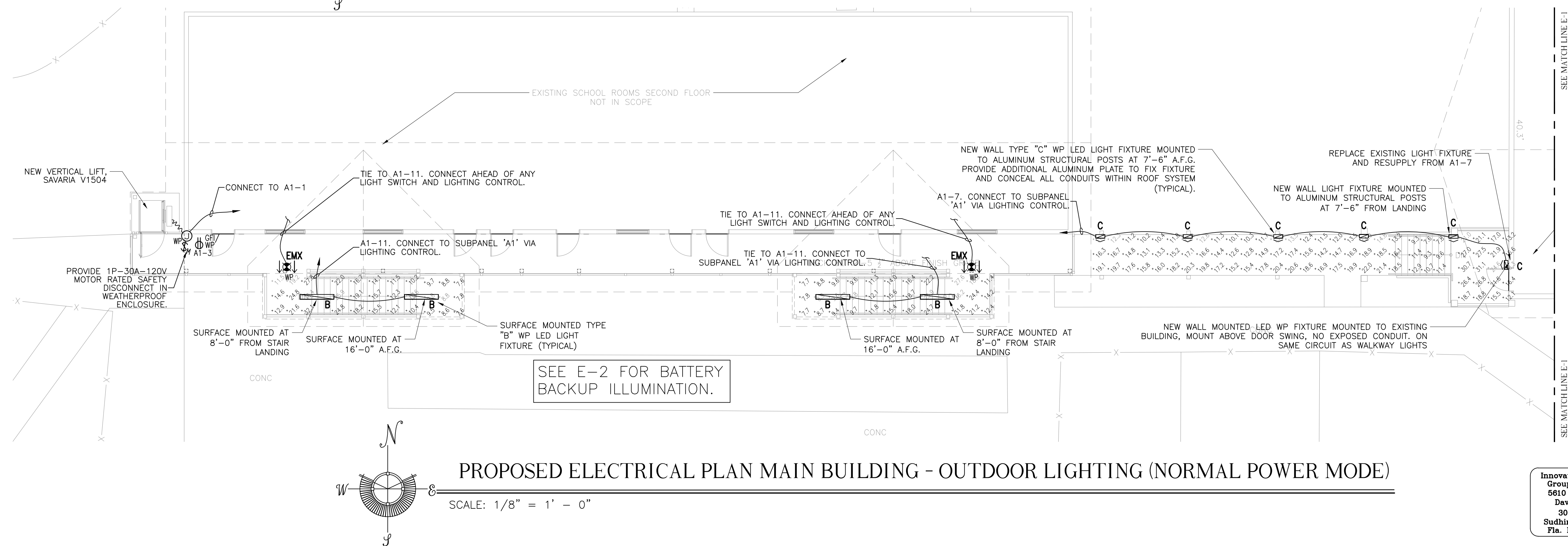

PROPOSED ELECTRICAL PLAN MAIN BUILDING - OUTDOOR LIGHTING (NORMAL POWER MODE)

SCALE: 1/8" = 1' - 0"

SEAL

DATE
01-14-2022

REVISIONS

DRAWN BY
JFS

PROJECT NUMBER
2105

Innovative Engineering
Group Inc. Reg. #6717
5610 Carriage Lane
Davie, FL 33331
305-302-5839
Sudhir K. Gupta, P.E.
Fla. Reg. No. 29189

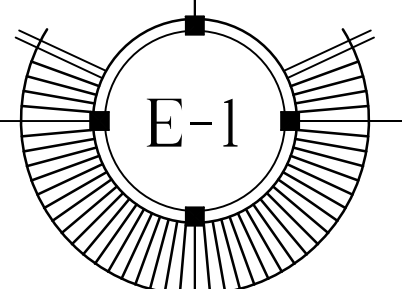

SCHEDULE - BASE OF THE ILLUMINATION LEVELS DESIGN.

Symbol	Label	Quantity	Manufacturer	Catalog Number	Description	Number Lamps	Filename	Lumens Per Lamp	Light Loss Factor	Wattage
	B	4	Lithonia Lighting	VAP 6000LM PCL MD 40K 80CRI	VAP LED with BLT Gen 2 Boards W/BATTERY BACKUP	1	VAP_6000LM_PCL_MD_40K_80CRI.ies	6324.8	0.9	49.3
	C	18	Lithonia Lighting	ARC1 LED P3 40K	ARC1 LED WITH P3 - PERFORMANCE PACKAGE, 4000K W/BATTERY BACKUP	1	ARC1_LED_P3_40K.ies	3020.5	0.9	24.5

IMPORTANT NOTE: CONTRACTOR TO RESUBMIT PHOTOMETRIC ILLUMINATION LEVELS PLANS AND STATISTICS IF USE SUBSTITUTION LIGHTING FIXTURE SCHEDULE COMPLYING REQUIRED ILLUMINATION LEVELS PER FLORIDA BUILDING AND LIFE SAFETY CODES.

Statistics - NORMAL POWER ILLUMINATION

Description	Symbol	Avg	Max	Min	Max/Min	Avg/Min
CONNECTOR	+	15.4 fc	22.0 fc	10.1 fc	2.2:1	1.5:1
CONNECTOR STAIR LAND	+	21.3 fc	31.1 fc	12.1 fc	2.6:1	1.8:1
CONNECTOR STAIR STEP 1	+	9.6 fc	11.4 fc	7.8 fc	1.5:1	1.2:1
CONNECTOR STAIR STEP 2	+	9.2 fc	10.7 fc	7.6 fc	1.4:1	1.2:1
CONNECTOR STAIR STEP 3	+	11.2 fc	12.9 fc	9.3 fc	1.4:1	1.2:1
EGRESS STAIR 1 - TOP	+	22.3 fc	36.4 fc	11.5 fc	3.2:1	1.9:1
EGRESS STAIR 1 GROUND	+	8.7 fc	9.8 fc	7.6 fc	1.3:1	1.1:1
EGRESS STAIR 1 STEP 1	+	24.2 fc	25.9 fc	22.0 fc	1.2:1	1.1:1
EGRESS STAIR 1 STEP 2	+	18.0 fc	19.1 fc	16.7 fc	1.1:1	1.1:1
EGRESS STAIR 1 STEP 3	+	15.1 fc	15.7 fc	14.1 fc	1.1:1	1.1:1
EGRESS STAIR 1 STEP 4	+	12.0 fc	12.3 fc	11.5 fc	1.1:1	1.0:1
EGRESS STAIR 1 STEP 5	+	10.4 fc	10.6 fc	10.2 fc	1.0:1	1.0:1
EGRESS STAIR 2 - TOP	+	17.7 fc	18.7 fc	16.4 fc	1.1:1	1.1:1
EGRESS STAIR 2 - GROUND	+	8.7 fc	9.6 fc	7.7 fc	1.2:1	1.1:1
EGRESS STAIR 2 STEP 1	+	24.3 fc	25.9 fc	22.2 fc	1.2:1	1.1:1
EGRESS STAIR 2 STEP 3	+	15.0 fc	15.6 fc	14.0 fc	1.1:1	1.1:1
EGRESS STAIR 2 STEP 4	+	11.7 fc	12.1 fc	11.3 fc	1.1:1	1.0:1
EGRESS STAIR 2 STEP 5	+	9.7 fc	9.8 fc	9.6 fc	1.0:1	1.0:1
RAMP 1	+	16.3 fc	26.1 fc	10.6 fc	2.5:1	1.5:1
RAMP 1 LAND	+	16.9 fc	25.9 fc	12.5 fc	2.1:1	1.4:1
RAMP 2	+	24.6 fc	30.1 fc	21.1 fc	1.4:1	1.2:1
RAMP 2 LAND	+	21.4 fc	32.7 fc	12.5 fc	2.6:1	1.7:1
RAMP 3	+	23.8 fc	30.5 fc	18.3 fc	1.7:1	1.3:1
RAMP LAND	+	14.7 fc	28.9 fc	5.0 fc	5.8:1	2.9:1
RAMP STAIR STEP 1	+	12.2 fc	13.1 fc	11.4 fc	1.1:1	1.1:1
RAMP STAIR STEP 2	+	9.4 fc	10.5 fc	8.4 fc	1.3:1	1.1:1

Statistics - BATTERY BACKUP ILLUMINATION

Description	Symbol	Avg	Max	Min	Max/Min	Avg/Min
CONNECTOR	+	2.7 fc	10.4 fc	0.5 fc	20.8:1	5.4:1
CONNECTOR STAIR LAND	+	3.6 fc	11.7 fc	0.4 fc	29.3:1	9.0:1
CONNECTOR STAIR STEP 1	+	1.8 fc	2.7 fc	1.0 fc	2.7:1	1.8:1
CONNECTOR STAIR STEP 2	+	1.0 fc	1.3 fc	0.7 fc	1.9:1	1.4:1
CONNECTOR STAIR STEP 3	+	0.8 fc	1.0 fc	0.6 fc	1.7:1	1.3:1
EGRESS STAIR 1 - TOP	+	2.7 fc	8.9 fc	0.5 fc	17.8:1	5.4:1
EGRESS STAIR 1 GROUND	+	3.6 fc	5.0 fc	2.0 fc	2.5:1	1.8:1
EGRESS STAIR 1 STEP 1	+	7.4 fc	10.0 fc	5.4 fc	1.9:1	1.4:1
EGRESS STAIR 1 STEP 2	+	2.3 fc	2.5 fc	2.1 fc	1.2:1	1.1:1
EGRESS STAIR 1 STEP 3	+	1.6 fc	1.7 fc	1.5 fc	1.1:1	1.1:1
EGRESS STAIR 1 STEP 4	+	2.1 fc	2.3 fc	1.9 fc	1.2:1	1.1:1
EGRESS STAIR 1 STEP 5	+	4.3 fc	4.8 fc	3.6 fc	1.3:1	1.2:1
EGRESS STAIR 2 - TOP	+	1.8 fc	2.0 fc	1.6 fc	1.3:1	1.1:1
EGRESS STAIR 2 - GROUND	+	3.4 fc	11.4 fc	0.6 fc	19.0:1	5.7:1
EGRESS STAIR 2 GROUND	+	3.2 fc	4.9 fc	1.4 fc	3.5:1	2.3:1
EGRESS STAIR 2 STEP 1	+	6.0 fc	8.3 fc	4.3 fc	1.9:1	1.4:1
EGRESS STAIR 2 STEP 3	+	1.7 fc	1.8 fc	1.6 fc	1.1:1	1.1:1
EGRESS STAIR 2 STEP 4	+	2.5 fc	2.7 fc	2.3 fc	1.2:1	1.1:1
EGRESS STAIR 2 STEP 5	+	4.7 fc	5.2 fc	4.1 fc	1.3:1	1.1:1
RAMP 1	+	2.7 fc	11.4 fc	0.6 fc	19.0:1	4.5:1
RAMP 1 LAND	+	2.1 fc	7.9 fc	0.6 fc	13.2:1	3.5:1
RAMP 2	+	4.1 fc	10.3 fc	1.2 fc	8.6:1	3.4:1
RAMP 2 LAND	+	3.0 fc	16.2 fc	0.4 fc	40.5:1	7.5:1
RAMP 3	+	2.6 fc	10.1 fc	0.6 fc	16.8:1	4.3:1
RAMP LAND	+	2.3 fc	13.0 fc	0.2 fc	65.0:1	11.5:1
RAMP STAIR STEP 1	+	3.9 fc	6.8 fc	1.5 fc	4.5:1	2.6:1
RAMP STAIR STEP 2	+	4.2 fc	6.9 fc	1.6 fc	4.3:1	2.6:1

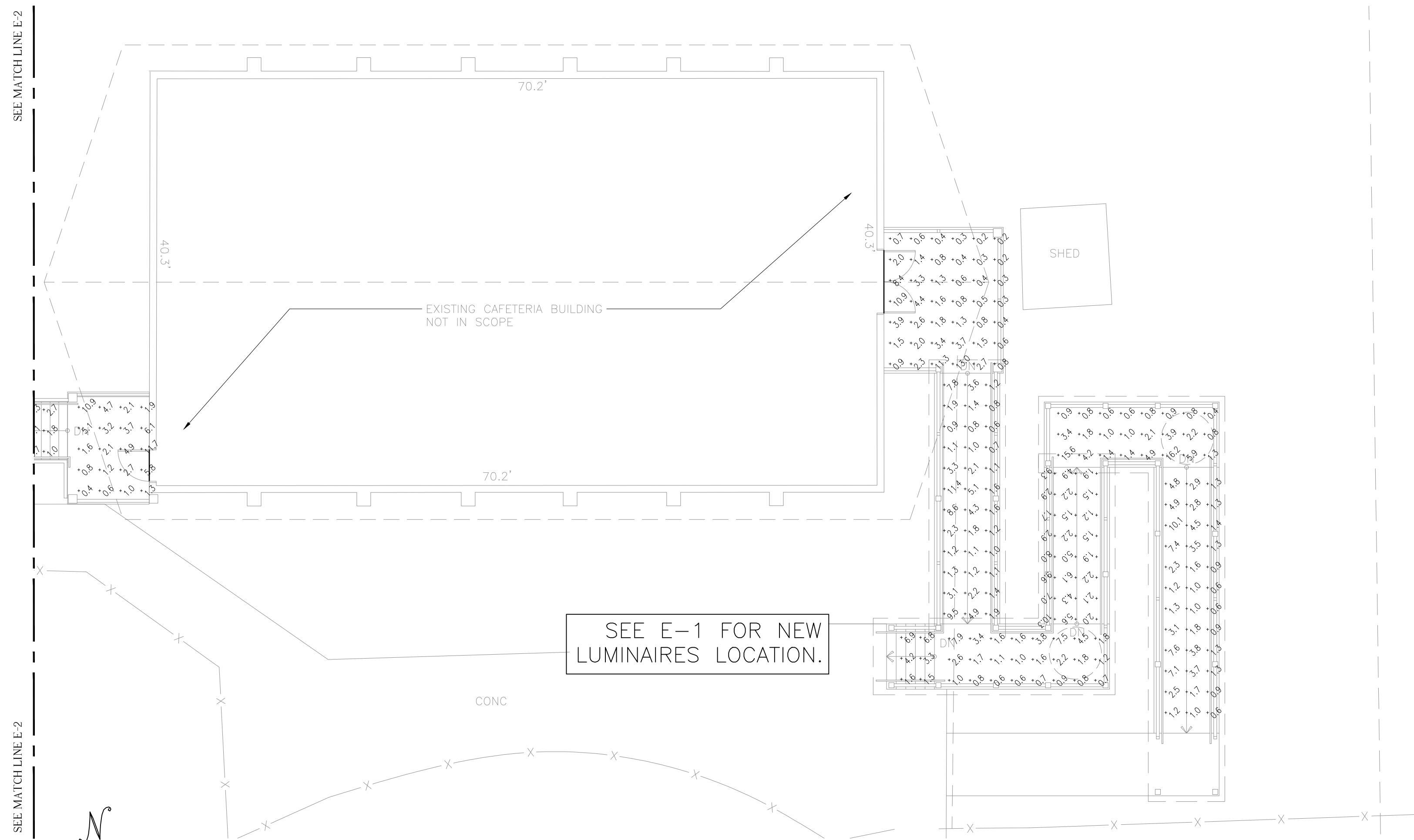

PROPOSED PLAN CAFETERIA BUILDING - OUTDOOR LIGHTING (BATTERY BACKUP MODE)

SCALE: 1/8" = 1' - 0"

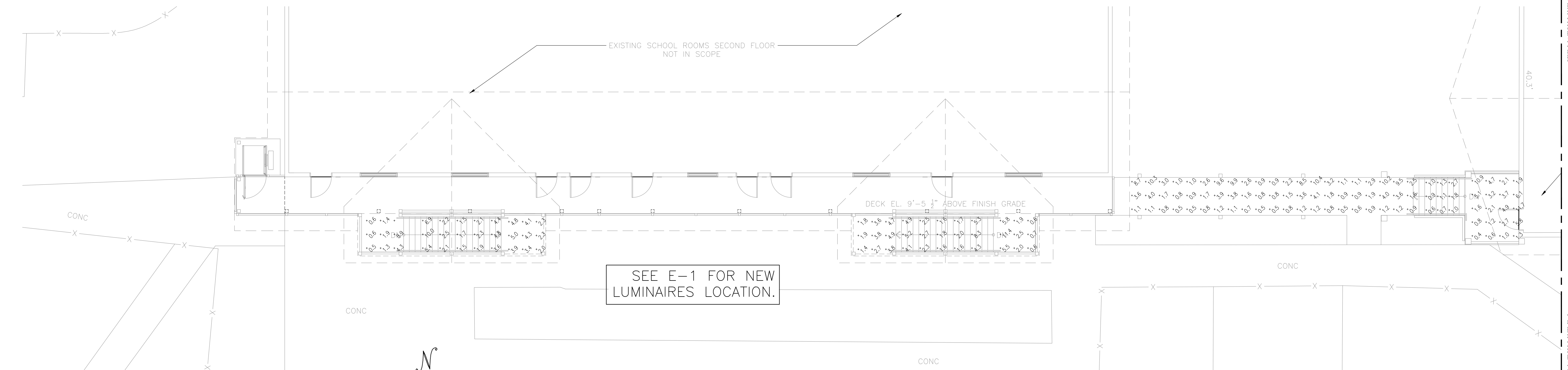
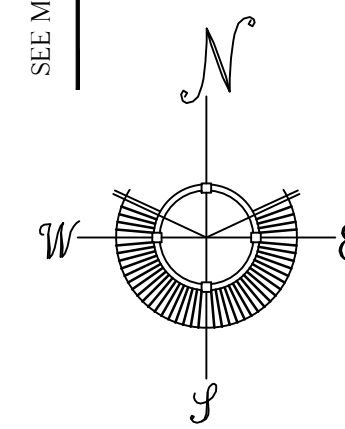

PROPOSED PLAN MAIN BUILDING - OUTDOOR LIGHTING (BATTERY BACKUP MODE)

SCALE: 1/8" = 1' - 0"

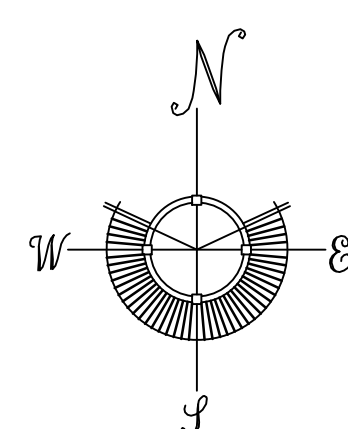

Innovative Engineering
Group Inc. Reg. #6717
5610 Carriage Lane
Davie, FL 33331
305-302-5839
Sudhir K. Gupta, P.E.
Fla. Reg. No. 29189

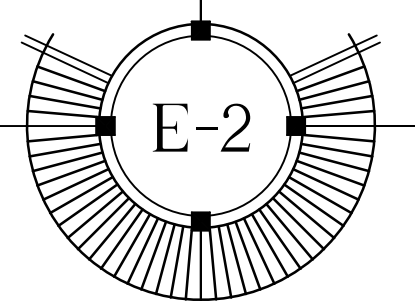

EQUAL TO: SQUARE D				PANEL "A" (EXISTING)								VOLTAGE: 120/240V, 1PH, 3W										
TYPE: LOAD CENTER				10k AIC RATING								MAINS AMPS: 225AMPS										
MOUNTING: EXISTING				PHASE (KVA)				CIRCUIT				CIRCUIT				PHASE (KVA)						
NO.	LOAD DESCRIPTION	L1	L2	BKR	P	W	C	C	W	P	BKR	L1	L2	LOAD DESCRIPTION	NO.							
1	EXIST. A/C SYSTEM 3	2.05		20	2	12	1/2"	1/2"	12	1	20	0.10		SMOKE DETECTOR	2							
3			2.05					1/2"	12	1	20		1.10	LIGHTING	4							
5	EXIST. A/C SYSTEM 2	2.05		20	2	12	1/2"	1/2"	12	1	20	1.10		LIGHTING	6							
7			2.05					1/2"	12	1	20		1.10	LIGHTING	8							
9	EXIST. A/C SYSTEM 1	2.05		20	2	12	1/2"	1/2"	12	1	20	1.10		LIGHTING	10							
11			2.05					1/2"	12	1	20		1.50	DRINKING FOUNTAIN	12							
13	EXIST. A/C SYSTEM 4	2.05		20	2	12	1/2"	1/2"	12	1	20	1.50		DRINKING FOUNTAIN	14							
15			2.05					1/2"	12	1	20		1.20	PROJECTOR	16							
17	RECEPTACLES	1.35		20	1	12	1/2"	1/2"	12	1	20	1.20		PROJECTOR	18							
19	RECEPTACLES		1.35	20	1	12	1/2"	1/2"	12	1	20		1.20	PROJECTOR	20							
21	RECEPTACLES	1.35		20	1	12	1/2"	1/2"	12	1	20	1.20		PROJECTOR	22							
23	RECEPTACLES		1.35	20	1	12	1/2"	-	-	1	20		1.20	SPARE	24							
25	RECEPTACLES	1.35		20	1	12	1/2"	1/2"	12	1	20	0.20		FIRE ALARM	26							
27	RECEPTACLES (NOTE 1)		1.35	20	1	12	1/2"	1/2"	12	1	20		1.35	RECEPTACLES	28							
29	SPARE	-		1	-	-	-	1/2"	12	1	20	1.35		RECEPTACLES	30							
												SUBTOTAL	12.26	12.26	NOTES:				7.75	8.65	40.92	
												(1) DISCONNECT EXISTING WIRING AND EXTEND TO NEW SUB-PANEL "A1"										
CONTINUOUS LOAD @ 125%:				5.9 KVA																		
NON-CONTINUOUS LOAD @ 100%:				36.5 KVA																		
				42.4 KVA																		
				176.6 AMPS																		

EQUAL TO: SQUARE D				PANEL "A" (EXISTING - MODIFIED)								VOLTAGE: 120/240V, 1PH, 3W										
TYPE: LOAD CENTER				10k AIC RATING								MAINS AMPS: 225AMPS										
MOUNTING: EXISTING				PHASE (KVA)				CIRCUIT				CIRCUIT				PHASE (KVA)						
NO.	LOAD DESCRIPTION	L1	L2	BKR	P	W	C	C	W	P	BKR	L1	L2	LOAD DESCRIPTION	NO.							
1	EXIST. A/C SYSTEM 3	2.05		20	2	12	1/2"	1/2"	12	1	20	0.10		SMOKE DETECTOR	2							
3			2.05					1/2"	12	1	20		1.10	LIGHTING	4							
5	EXIST. A/C SYSTEM 2	2.05		20	2	12	1/2"	1/2"	12	1	20	1.10		LIGHTING	6							
7			2.05					1/2"	12	1	20		1.10	LIGHTING	8							
9	EXIST. A/C SYSTEM 1	2.05		20	2	12	1/2"	1/2"	12	1	20	1.10		LIGHTING	10							
11			2.05					1/2"	12	1	20		1.50	DRINKING FOUNTAIN	12							
13	EXIST. A/C SYSTEM 4	2.05		20	2	12	1/2"	1/2"	12	1	20	1.50		DRINKING FOUNTAIN	14							
15			2.05					1/2"	12	1	20		1.20	PROJECTOR	16							
17	RECEPTACLES	1.35		20	1	12	1/2"	1/2"	12	1	20	1.20		PROJECTOR	18							
19	RECEPTACLES		1.35	20	1	12	1/2"	1/2"	12	1	20		1.20	PROJECTOR	20							
21	RECEPTACLES	1.35		20	1	12	1/2"	1/2"	12	1	20	1.20		PROJECTOR	22							
23	RECEPTACLES		1.35	20	1	12	1/2"	-	-	1	20		1.20	SPARE	24							
25	RECEPTACLES	1.35		20	1	12	1/2"	1/2"	12	1	20	0.20		FIRE ALARM	26							
27	RECEPTACLES		1.35	20	1	12	1/2"	1/2"	12	1	20		1.35	RECEPTACLES	28							
29	NEW SUB-PANEL "A1" (NOTE 1)	2.10		60	2	6	1"	1/2"	12	1	20	1.35		RECEPTACLES	30							
												SUBTOTAL	14.36	13.03	NOTES:				7.75	8.65	43.79	
												(1) PROVIDE NEW CIRCUIT BREAKER. MATCH PANEL AND CBS MECHANICAL AND ELECTRICAL CHARACTERISTICS.										
CONTINUOUS LOAD @ 125%:				6.84 KVA																		
NON-CONTINUOUS LOAD @ 100%:				38.3 KVA																		
				45.2 KVA																		
				188.2 AMPS																		

EQUAL TO: SCHNEIDER ELECTRIC				SUBPANEL "A1" (NEW)								VOLTAGE: 120/240V, 1PH, 3W										
TYPE: LOAD CENTER				10k AIC RATING								MAINS AMPS: 125AMPS										
MOUNTING: SURFACE - NEMA 1				PHASE (KVA)				CIRCUIT				CIRCUIT				PHASE (KVA)						
NO.	LOAD DESCRIPTION	L1	L2	BKR	P	W	C	C	W	P	BKR	L1	L2	LOAD DESCRIPTION	NO.							
1	SAVARIA V1504 VERTIC LIFT (NOTE 2)	1.92		-	-	-	-	1/2"	-	-	-	-	-	SPACE	2							
3	SPACE			-	-	-	-	1/2"	12	1	20		1.35	RECEPTS CKT - PANEL "A" (NOTE 4)	4							
5	CONVENIENCE RECEPTACLE	0.18		20	1	12	1/2"	-	-	-	-	-	-	SPACE	6							
7	CORR. CONNECT LIGHTS (NOTE 3)		0.13	20	1	12	1/2"	-	-	1	20	-	-	SPACE	8							
9	SPACE			-	-	-	-	-	-	-	-	-	-	SPACE	10							
11	STAIRS LIGHTS/EXIT SIGNS (NOTE 3)		0.40	20	1	12	1/2"	-	-	1	20	-	-	SPACE	12							
13	SPACE			-	-	-	-	-	-	-	-	-	-	SPACE	14							
15	NEW RAMP LIGHTS (NOTE 3)		0.25	20	1	12	1/2"	3/4"	10	2	30	-	-	SURGE SUPPRESSOR DEVICE (NOTE 1)	16							
												SUBTOTAL	2.10	0.78	NOTES:				0.00	1.35	4.23	
												(1) PROVIDE NEW SURGE SUPPRESSOR DEVICE.										
												(2) PROVIDE GFI CIRCUIT BREAKER										
												(3) CONNECT THRU LIGHTING CONTACTOR AND TIME SWITCH. CONSTROLS INSTALLED OUTDOOR PROVIDE ALL IN SS ENCLOSURE NEMA 4X. SET TIME SWITCH AS REQUIRED BY OWNER.										
												(4) RECEPTACLES CIRCUIT TRANSFERRED FROM PANEL "A"										
CONTINUOUS LOAD @ 125%:				0.97 KVA																		
NON-CONTINUOUS LOAD @ 100%:				3.5 KVA																		
				4.4 KVA																		
				18.4 AMPS																		

BIG PINE ACADEMY - LUMINAIRE FIXTURE SCHEDULE						
TYPE	MANUFACTURER & CATALOG No.	MOUNTING	LAMPS TYPE	WATTS	FIXTURE SERVICE VOLTS	REMARKS
EMX	LITHONIA LIGHTING LED EXIT LIGHT - LV EL N LV S W 2 R 120/277 EL N UM F FI 4X SD	UNIVERSAL MOUNT	LED	4.8	120/277V	LOCATED AT MAIN BUILDING STAIRS. WET LOCATION RATED, EMERGENCY BATTERY PACK.
B	LITHONIA LIGHTING ROUGH SERVICE FIXTURE VAP LED 6000LM PCL MD MVOLT G210 40K 80CRI E15WC SPD WLF STSL GMB	SURFACE/ CEILING	LED	50	MVOLT	LOCATED AT OUTDOOR CONNECTOR CORRIDOR AND RAMP. WET LOCATION RATED, SURGE SUPPRESSOR DEVICE, EMERGENCY BATTERY PACK - 15W CONSTANT POWER
C	LITHONIA LIGHTING ARCHITECTURAL WALL LUMINAIRE FIXTURE ARC1 LED P3 40K MVOLT E4WH PE SPD6KV FAO DNAXD WSBBW DDBXD U	SURFACE/ WALL MOUNTED	LED	25	MVOLT	LOCATED AT MAIN BUILDING STAIRS. WET LOCATION RATED, SURGE SUPPRESSOR DEVICE, EMERGENCY BATTERY PACK - 4W CONSTANT POWER, PHOTOCELL, PROVIDE STANDARD BACK BOX.

GENERAL ELECTRICAL NOTES

- ALL WORK SHALL BE IN ACCORDANCE WITH NATIONAL ELECTRICAL CODE, FLORIDA BUILDING CODE AND OTHER APPLICABLE CODES AND STANDARDS.
- THE DRAWINGS ARE DIAGRAMMATIC AND DO NOT SHOW ALL OFFSETS, BENDS AND BOXES REQUIRED TO MAKE A COMPLETE NEAT INSTALLATION IN ACCORDANCE WITH N.E.C.
- WHEN CONFLICTS ARISE IN LOCATIONS WIRING DEVICES, ELECTRICAL EQUIPMENT, DISCONNECTS, PANELBOARDS, ETC. DUE TO FIELD CONDITION OR IMPROPER FIELD COORDINATION CONTRACTOR SHALL BRING IT TO THE A/E'S ATTENTION AND AT NO EXTRA COST RELOCATE, AND OR EXTEND WITHIN A REASONABLE DISTANCE SUCH ITEM WHICH IS IN CONFLICT. THE CONTRACTOR IS RESPONSIBLE FOR COORDINATING LOCATION OF ALL COMPONENTS PRIOR TO ROUGH IN WITH ALL TRADES NO EXTRAS WILL BE ALLOWED FOR FAILURE TO DO SO.
- THE CONTRACTOR IS RESPONSIBLE FOR EVALUATING FIELD CONDITIONS BY VISITING THE SITE PRIOR TO COMMENCING / BIDDING WORK.
- THE CONTRACTOR SHALL SATISFACTORILY REPAIR / REPLACE EQUIPMENT OR PART OF STRUCTURE DAMAGED AS A RESULT OF HIS WORK. SURFACES AND FINISHED AREAS SHALL BE RESTORED TO MATCH ADJACENT AREAS.
- INSTALL POWER AND CONTROL WIRING AS REQUIRED BY SYSTEMS MANUFACTURER.
- ALL MATERIAL REMOVED SHALL BE DISPOSED OF AS DIRECTED BY OWNER.
- MINIMUM WIRE SIZE SHALL BE # 12 THWN UNLESS OTHERWISE NOTED ON PLANS.
- ALL CONDUCTORS SHALL BE COPPER.
- ALL CONDUCTORS SHALL BE RUN IN CONDUIT. IF PVC SCHEDULE 40 IS USED, AN EQUIPMENT GROUND CONDUCTOR SIZED IN ACCORDANCE WITH N.E.C. 250-122 MUST BE INSTALLED AND CONDUIT SIZE INCREASED AS REQUIRED. PROVIDE A GREEN GROUNDING CONDUCTOR TO ALL BRANCH CIRCUITS. SIZE OF NEUTRAL CONDUCTOR SHALL BE THE SAME SIZE AS PHASE CONDUCTORS.
- IF PVC SCHEDULE 40 IS USED FOR UNDERGROUND AND SCHEDULE 80 IS USED FOR ABOVE GROUND CIRCUITS, AN EQUIPMENT GROUND CONDUCTOR SIZED IN ACCORDANCE WITH N.E.C. 250-122 MUST BE INSTALLED AND CONDUIT SIZE INCREASED AS REQUIRED.
- ALL MATERIALS SHALL BE U.L. APPROVED.
- NEW TYPEWRITTEN PANEL TALLY SHALL BE FURNISHED AFTER JOB IS COMPLETED.
- ALL BRANCH CIRCUITS SHALL BE PROPERLY PHASE BALANCED.
- ALUMINUM CONDUITS ARE NOT ALLOWED.
- ALL EMPTY CONDUITS TO BE PROVIDED WITH NYLON PULL STRINGS.
- FUSES SHALL BE DUAL ELEMENT, TIME DELAY TYPE UNLESS OTHERWISE NOTED.
- ALL LUMINARIES SHALL BE PROPERLY SUPPORTED IN ACCORDANCE WITH MANUFACTURER RECOMMENDATIONS AND LOCAL CODE REQUIREMENTS.
- RISERS ARE DIAGRAMMATIC ONLY. THEY DO NOT SHOW EVERY BEND REQUIRED FOR THE INSTALLATION.
- EQUIPMENT WIRING AND BREAKER SHALL BE BASED ON EQUIPMENT MANUFACTURER RECOMMENDATIONS. CONTRACTOR IS RESPONSIBLE FOR PROVIDING ALL WIRING, BREAKER AND FUSES SIZES IN ACCORDANCE WITH MFR NAMEPLATE REQUIREMENTS IF DIFFERENT FROM THAT SPECIFIED ON DRAWINGS, AS WELL AS ANY FEEDER CHANGES BEING AFFECTED BY THIS CHANGE CONTRACTOR SHALL MAKE ABOVE MENTIONED CHANGES AT NO EXTRA COST.
- ALL RACEWAY ROUTED, INSULATED CONDUCTORS SYSTEM SHALL BE COLOR CODED AS FOLLOWS:
- ALL CABLES SHALL BE RUN WITH OUT SPLICES EXCEPT IF OTHERWISE INDICATED.
- ALL PULL AND JUNCTION BOXES SHALL BE ACCESSIBLE AT ALL TIMES.
- EXACT POINT AND METHODS OF CONNECTION SHALL BE DETERMINED IN FIELD.
- ALL WORK SHALL BE DONE IN A NEAT AND WORKMANLIKE MANNER.
- UTILITY POLE/METER AND OTHER OUTDOOR ELECTRICAL EQUIPMENT, INCLUDING TRANSFORMERS SHALL BE PROTECTED BY ACCIDENTAL CONTACT BY UNAUTHORIZED PERSONNEL OR VEHICLE AND SHALL COMPLY WITH ARTICLE 110.26 (F)(2).
- THIS DRAWING IS A GUIDE FOR THE ELECTRICAL INSTALLTION. THE ELECTRICAL CONTRACTOR IS RESPONSIBLE TO PROVIDE A FUNCTIONING SYSTEM.
- ALL OUTSIDE LIGHT FIXTURES SHALL BE WEATHER PROOF. RECEPTACLES SHALL BE WEATHER PROOF GFI TYPE. OUTSIDE PANELS SHALL HAVE NEMA 4X STAINLESS STEEL ENCLOSURE WITH LOCKS.
- CONTRACTOR SHALL PAY ALL FEES & INSURANCES REQUIRED TO DO THE WORK.
- ALL ELECTRICAL EQUIPMENT SHALL BE INSTALLED ABOVE FLOOD ELEVATION. ALL OUTDOOR ELECTRICAL EQUIPMENT SHALL HAVE NEMA 4X-SS ENCLOSURE WITH LOCK, UNLESS NOTED OTHERWISE.
- ALL RACEWAY ROUTED, INSULATED CONDUCTORS SYSTEM SHALL BE COLOR CODED AS FOLLOWS:
120/240 V AND 120/208 V SYSTEM 277/480 V SYSTEM
PHASE 'A' BLACK BROWN
PHASE 'B' RED PURPLE
PHASE 'C' BLUE YELLOW
NEUTRAL WHITE GRAY
GROUND GREEN GREEN
- COORDINATE LOCATION OF ALL EQUIPMENT IN THE FIELD.

ELECTRICAL LEGEND

- 120/277V WALL MOUNTED INTERIOR LIGHT ABOVE MIRROR
- 120/277V EXIT BATTERY BACK-UP LIGHT. CONNECTED AHEAD OF ANY LIGHT SWITCH/LIGHTING CONTROL.
- 120/277V LINEAR LED LIGHT FIXTURE SUSPENDED OR SURFACE MOUNTED WITH EMERGENCY BATTERY BACKUP DRIVER. CONNECT BACKUP DRIVER AHEAD OF ANY LIGHT SWITCH/LIGHTING CONTROL. WET LOCATION
- WP WATER PROOF ITEM
- WALL DUPLEX OUTLET
- CEILING OR WALL MOUNTED JUNCTION BOX
- MOTOR RATED SWITCH
- DISCONNECT SWITCH SIZED PER EQUIPMENT NAMEPLATE - "2" DENOTES # OF POLES, "60" DENOTES EQUIPMENT FRAME, "*" DENOTES FUSES BY MANUFACTURER RECOMMENDATIONS, "4X-SS" DENOTES NEMA ENCLOSURE TYPE (" " DENOTES NEMA 1)
- RECESSED ELECTRIC PANEL
- DISCONNECT SWITCH
- SURFACE MOUNTED ELECTRIC PANEL
- GFI GROUND FAULT INTERRUPTER
- FACP FIRE ALARM CONTROL PANEL
- FAA FIRE ALARM ANNUNCIATOR

ALL ELECTRICAL MATERIAL, LIGHTING, MACHINERY AND EQUIPMENT, ETC. MUST BE LISTED BY A NATIONALLY RECOGNIZED TESTING LAB (NRTL),

ABBREVIATIONS

- AIC AMPACITY INTERRUPTING CURRENT
- (E) EXISTING TO REMAIN
- E.C. EMPTY CONDUIT
- (N) NEW
- (Er) EXISTING TO BE REMOVED
- APPROX. APPROXIMATE
- A.B.G. ABOVE GROUND
- A.F.G. ABOVE FINISHED GROUND
- EM EMERGENCY LIGHT HARDWARE W/BATT. BACK UP. CONNECT AHEAD OF ANY LIGHT SWITCH OR LIGHTING CONTROL SYSTEM.
- EXT EXTERIOR
- GFI/GFI GROUND FAULT INTERRUPTER
- GRS GALVANIZED RIGID STEEL
- (G) (GND) GROUND/GROUNDING
- INT INTERIOR
- N.E.C. NATIONAL ELECTRIC CODE - NFPA 70
- PAV PAVILION
- REC RECEPTACLE(S), RECEPT(S)
- SS STAINLESS STEEL MARINE GRADE ENCLOSURE
- WP WEATHERPROOF ITEM
- WR WEATHER RESISTANCE

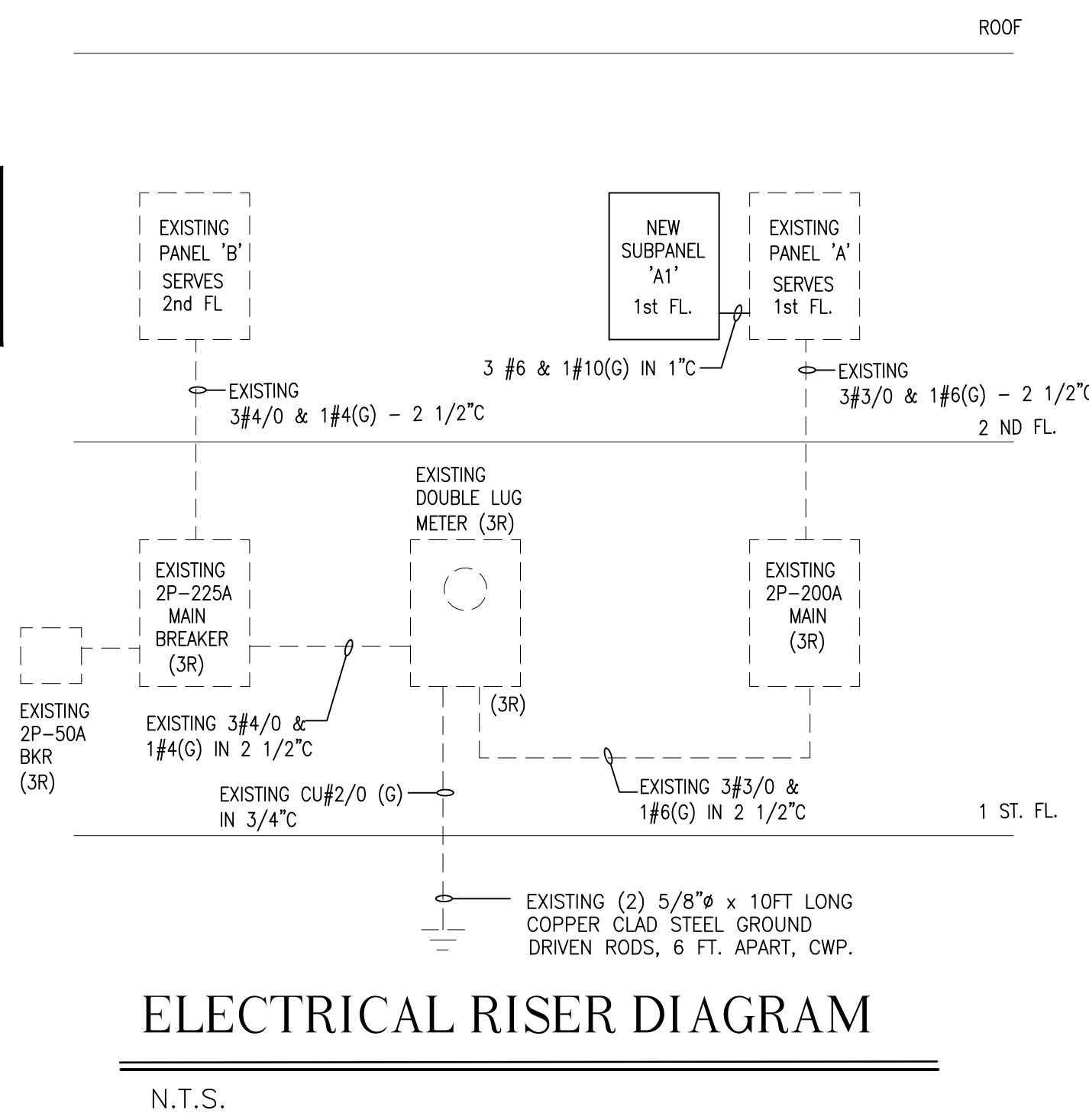

ELECTRICAL RISER DIAGRAM

- LEGEND:
- DENOTES EXISTING TO REMAIN
- DENOTES NEW WORK

Innovative Engineering Group Inc. Reg. #6717
5610 Carriage Lane
Davie, FL 33331
305-302-5839
Sudhir K. Gupta, P.E.
Fla. Reg. No. 29189

WILLIAM P. HORN
ARCHITECT, P.A.

915 EATON ST.
KEY WEST,
FLORIDA
33040

TEL (305) 296-8302
FAX (305) 296-1033

LICENSE NO.
AA 0003040

BIG PINE ACADEMY
ADA ACCESS
COMPLIANCE
RENOVATION
30220 OVERSEAS HWY.
BIG PINE KEY, FLORIDA

SEAL

DATE
01-14-2022

REVISIONS

DRAWN BY
JFS

PROJECT NUMBER
2105

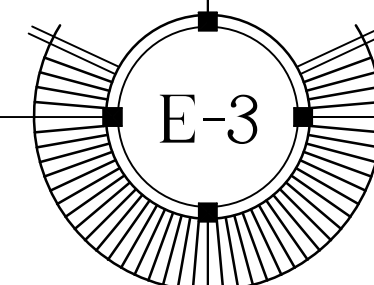

BIG PINE ACADEMY ADA ACCESS COMPLIANCE RENOVATION
30220 OVERSEAS HIGHWAY
BIG PINE KEY, FLORIDA 33043